

# Concurrent Strategies as Street Fibrations

Hugo Paquet, Inria & ENS, Paris

Glynn Winskel, Queen Mary University of London

# Concurrent strategies

A mathematical theory of games and strategies based on event structures.

*[Winskel–Rideau 2011, also Melliès, Faggian–Piccolo, Hirschowitz–Eberhart, Clairambault]*

# Concurrent strategies

A mathematical theory of games and strategies based on event structures.

**Event structures:** partial-order concurrency + non-determinism.

# Concurrent strategies

A mathematical theory of games and strategies based on event structures.

**Event structures:** partial-order concurrency + non-determinism.

**Def.** An *event structure* is a poset  $(E, \leq)$  with an irreflexive "conflict" relation  $\# \subseteq E \times E$  such that

# Concurrent strategies

A mathematical theory of games and strategies based on event structures.

**Event structures:** partial-order concurrency + non-determinism.

**Def.** An *event structure* is a poset  $(E, \leq)$  with an irreflexive "conflict" relation  $\# \subseteq E \times E$

such that

- every event  $e$  has a finite down-closure  $\{d \in E \mid d \leq e\}$
- the conflict is hereditary: if  $d \# d'$  and  $d \leq e$  then  $d' \# e$

# Concurrent strategies

A mathematical theory of games and strategies based on event structures.

**Event structures:** partial-order concurrency + non-determinism.

**Def.** An *event structure* is a poset  $(E, \leq)$  with an irreflexive "conflict" relation  $\# \subseteq E \times E$

- such that
- every event  $e$  has a finite down-closure  $\{d \in E \mid d \leq e\}$
  - the conflict is hereditary: if  $d \# d'$  and  $d \leq e$  then  $d' \# e$

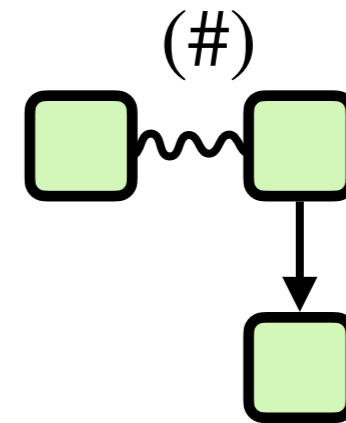

# Concurrent strategies

A mathematical theory of games and strategies based on event structures.

**Event structures:** partial-order concurrency + non-determinism.

**Def.** An *event structure* is a poset  $(E, \leq)$  with an irreflexive "conflict" relation  $\# \subseteq E \times E$

- such that
- every event  $e$  has a finite down-closure  $\{d \in E \mid d \leq e\}$
  - the conflict is hereditary: if  $d \# d'$  and  $d \leq e$  then  $d' \# e$

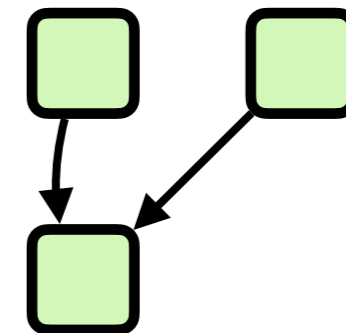
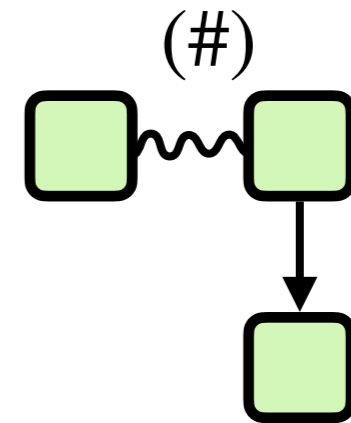

# Concurrent strategies

A mathematical theory of games and strategies based on event structures.

**Event structures:** partial-order concurrency + non-determinism.

**Def.** An *event structure* is a poset  $(E, \leq)$  with an irreflexive "conflict" relation  $\# \subseteq E \times E$

- such that
- every event  $e$  has a finite down-closure  $\{d \in E \mid d \leq e\}$
  - the conflict is hereditary: if  $d \# d'$  and  $d \leq e$  then  $d' \# e$

**Def.** A *configuration* is a finite, down-closed, conflict-free subset.    **Notation:**  $\mathcal{C}(E)$

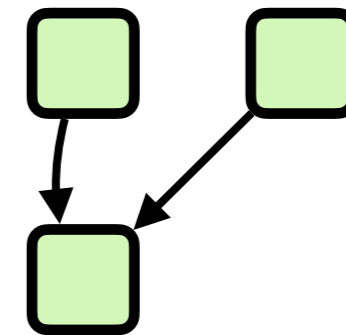
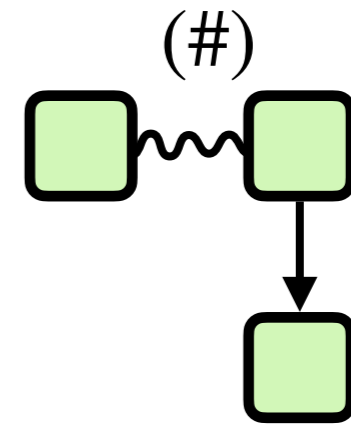

# Concurrent strategies

A mathematical theory of games and strategies based on event structures.

**Event structures:** partial-order concurrency + non-determinism.

**Def.** An *event structure* is a poset  $(E, \leq)$  with an irreflexive "conflict" relation  $\# \subseteq E \times E$

such that

- every event  $e$  has a finite down-closure  $\{d \in E \mid d \leq e\}$
- the conflict is hereditary: if  $d \# d'$  and  $d \leq e$  then  $d' \# e$

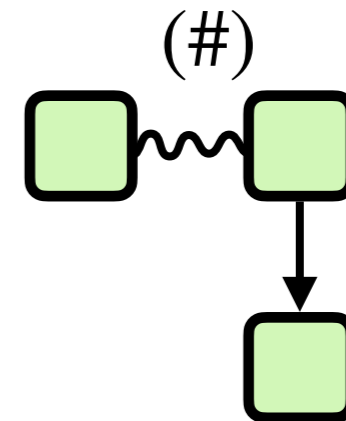

**Def.** A *configuration* is a finite, down-closed, conflict-free subset. **Notation:**  $\mathcal{C}(E)$

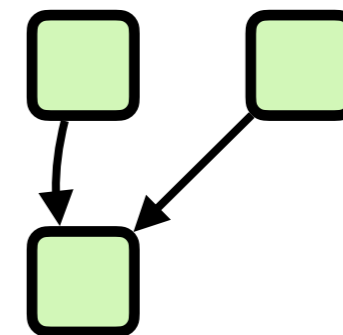

**Def.** A morphism  $(E, \leq, \#) \rightarrow (E', \leq', \#')$  is a function  $f : E \rightarrow E'$  which preserves configurations and is locally injective.

# Concurrent strategies

A mathematical theory of games and strategies based on event structures.

# Concurrent strategies

A mathematical theory of games and strategies based on event structures.

## Game

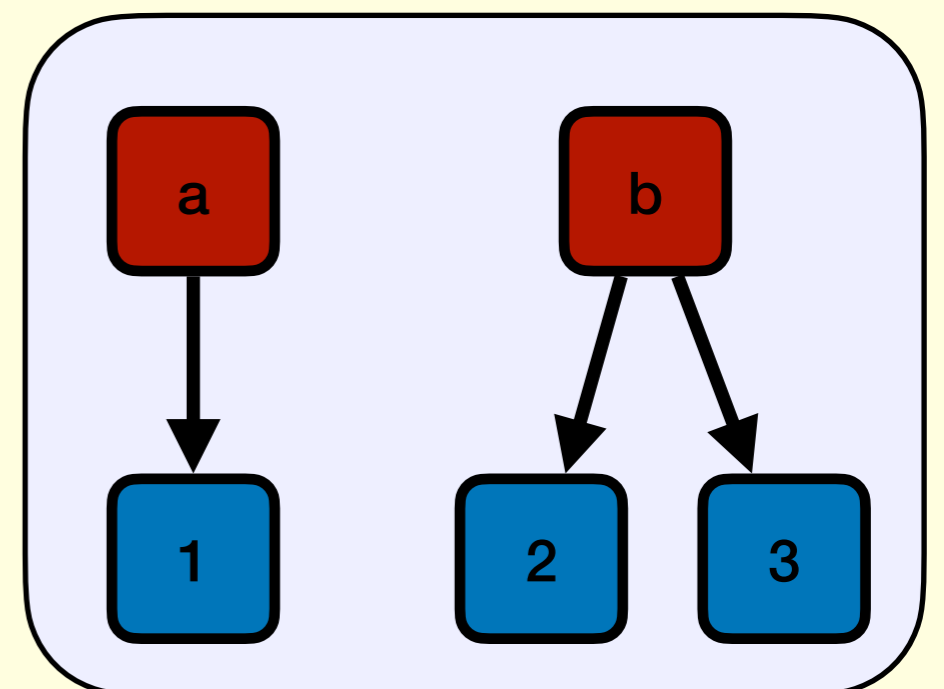

# Concurrent strategies

A mathematical theory of games and strategies based on event structures.

## Strategy

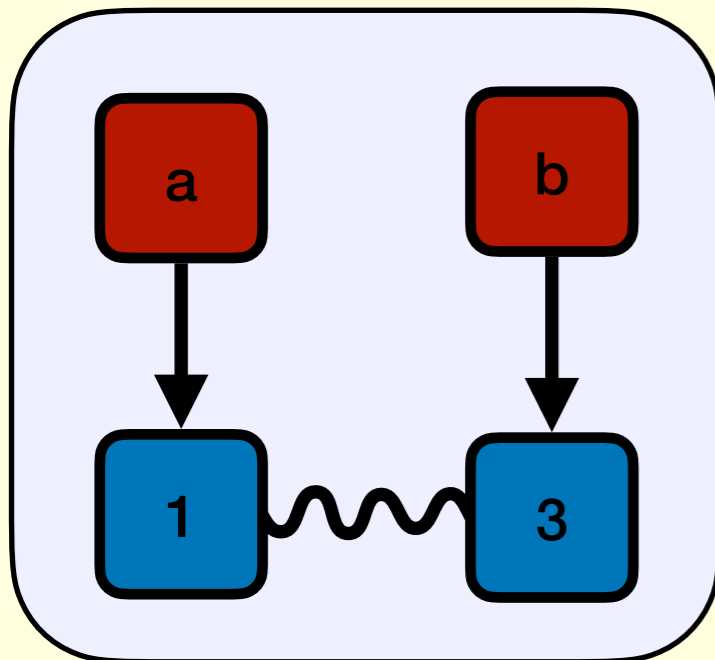

## Game

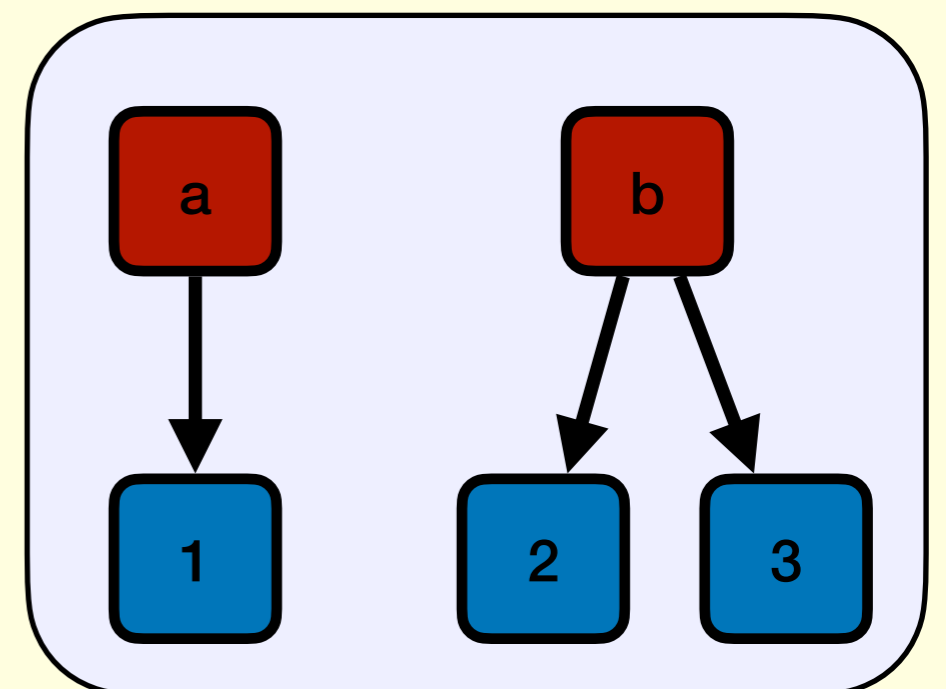

# Concurrent strategies

A mathematical theory of games and strategies based on event structures.

## Strategy

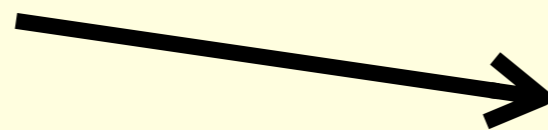
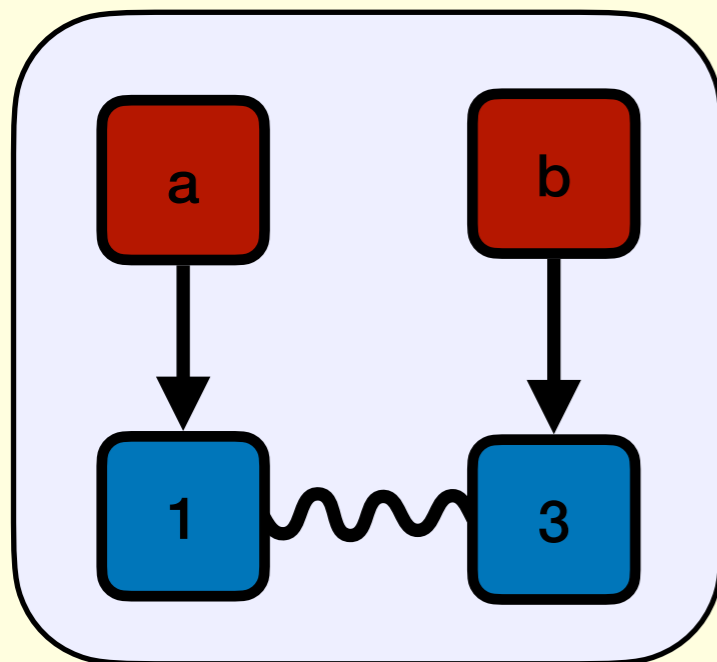

## Game

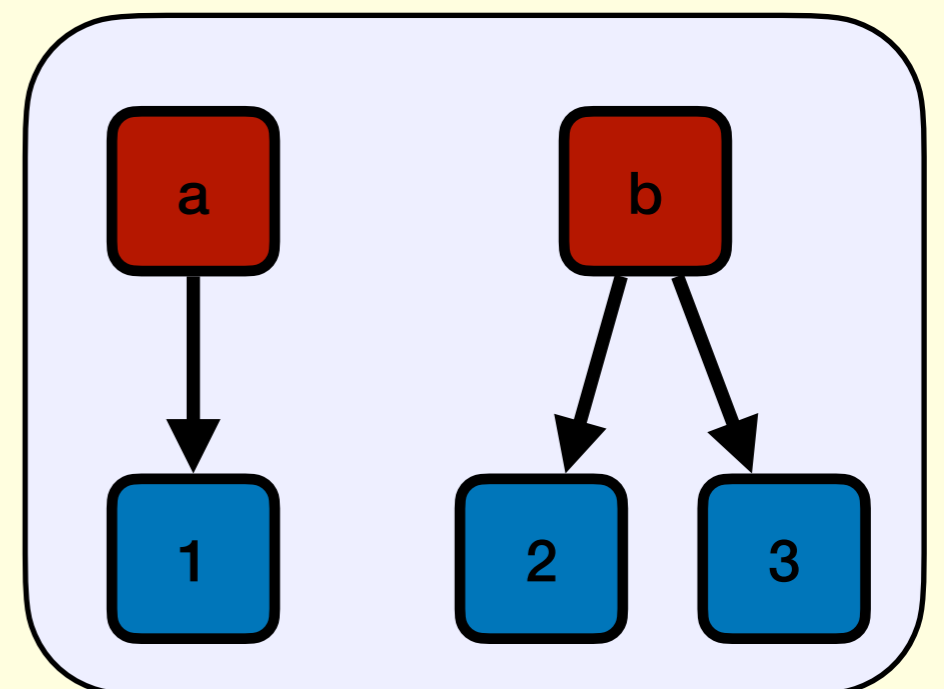

# Concurrent strategies

A **pre-strategy** on a game  $A$  is a pair  $(S, \sigma : S \rightarrow A)$ .

# Concurrent strategies

A **pre-strategy** on a game  $A$  is a pair  $(S, \sigma : S \rightarrow A)$ .

*Morphisms:*

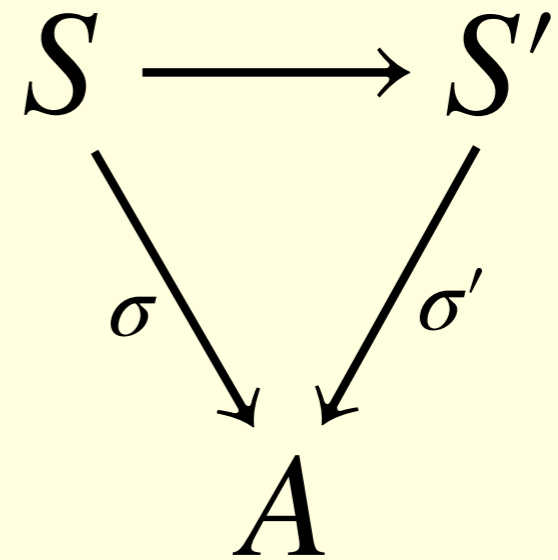

# Concurrent strategies

A **pre-strategy** on a game  $A$  is a pair  $(S, \sigma : S \rightarrow A)$ .

A **pre-strategy**  $A \dashv\rightarrow B$  is a pre-strategy on  $A^\perp \parallel B$ .

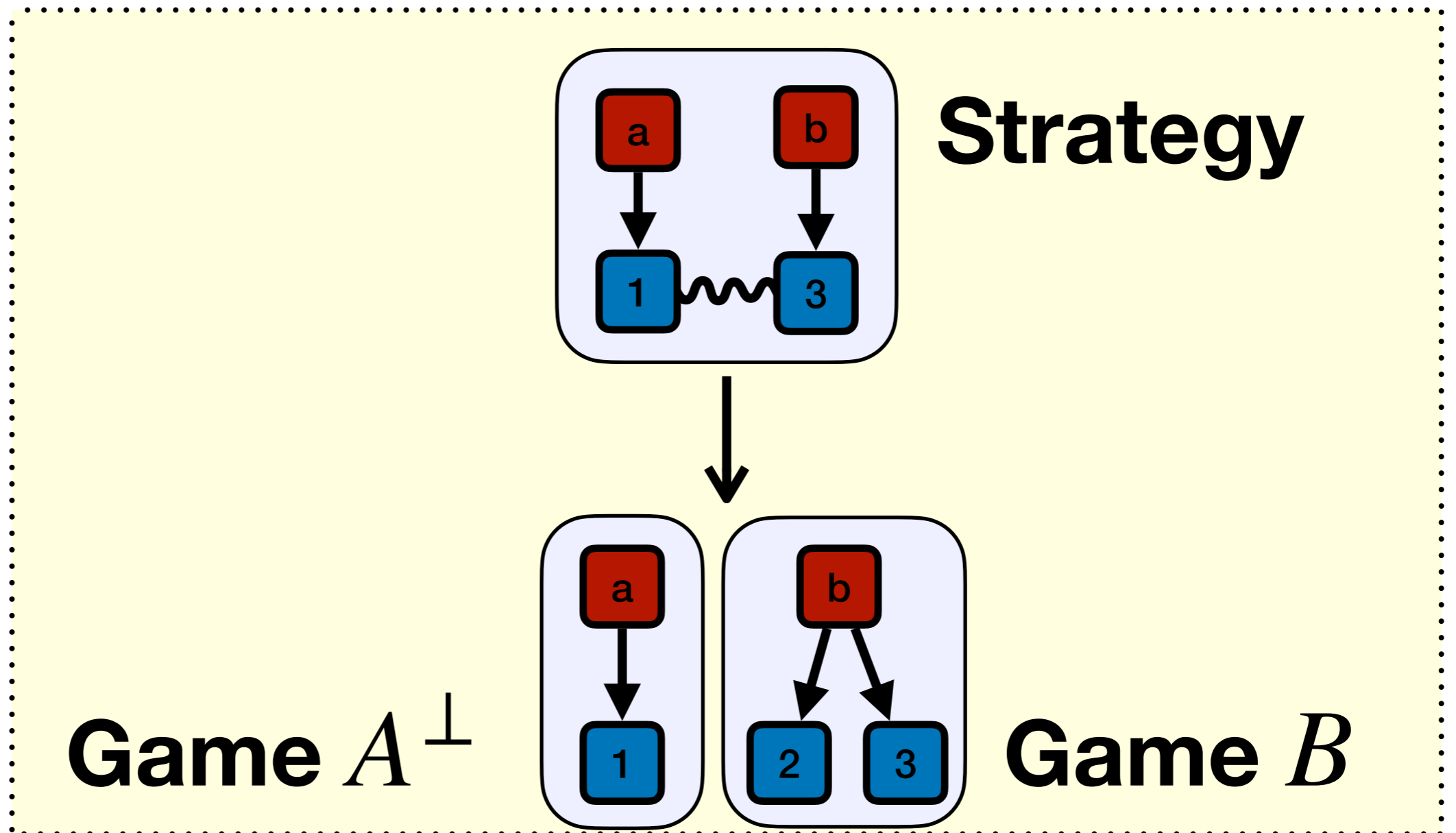

# Concurrent strategies

A **pre-strategy** on a game  $A$  is a pair  $(S, \sigma : S \rightarrow A)$ .

A **pre-strategy**  $A \dashv\rightarrow B$  is a pre-strategy on  $A^\perp \parallel B$ .

We can compose pre-strategies  $A \dashv\rightarrow B$  and  $B \dashv\rightarrow C$ .

# Concurrent strategies

A **pre-strategy** on a game  $A$  is a pair  $(S, \sigma : S \rightarrow A)$ .

A **pre-strategy**  $A \multimap B$  is a pre-strategy on  $A^\perp \parallel B$ .

We can compose pre-strategies  $A \multimap B$  and  $B \multimap C$ .

There is a "copycat" pre-strategy  $\text{id}_A : A \multimap A$ .

# Concurrent strategies

A **pre-strategy** on a game  $A$  is a pair  $(S, \sigma : S \rightarrow A)$ .

A **pre-strategy**  $A \dashv\rightarrow B$  is a pre-strategy on  $A^\perp \parallel B$ .

We can compose pre-strategies  $A \dashv\rightarrow B$  and  $B \dashv\rightarrow C$ .

There is a "copycat" pre-strategy  $\text{id}_A : A \dashv\rightarrow A$ .

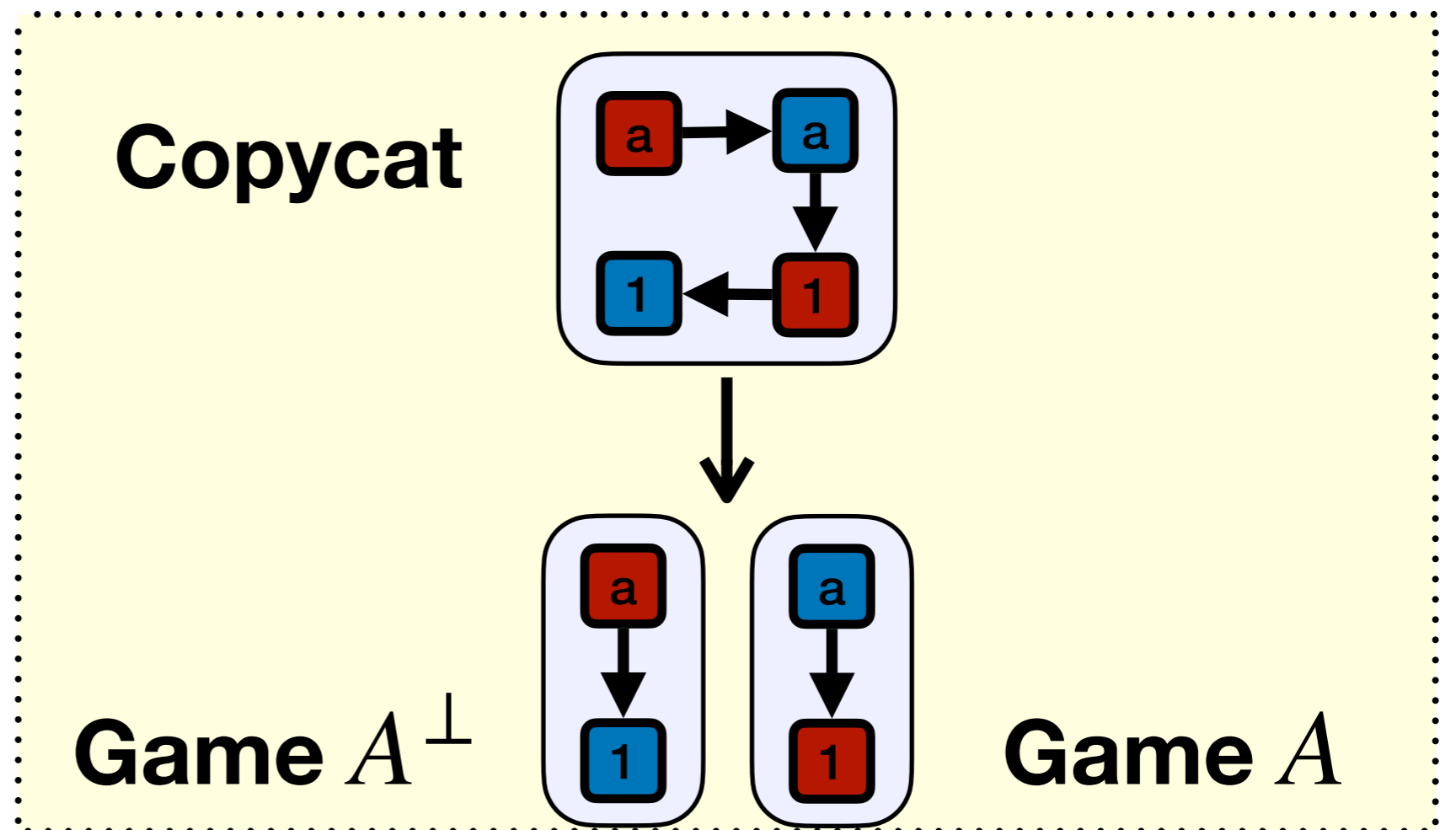

# Concurrent strategies

A **pre-strategy** on a game  $A$  is a pair  $(S, \sigma : S \rightarrow A)$ .

A **pre-strategy**  $A \multimap B$  is a pre-strategy on  $A^\perp \parallel B$ .

We can compose pre-strategies  $A \multimap B$  and  $B \multimap C$ .

There is a "copycat" pre-strategy  $\text{id}_A : A \multimap A$ .

**Def.** A **strategy**  $\sigma : A \multimap B$  is a pre-strategy such that  $\sigma \circ \text{id}_A \cong \sigma$  and  $\text{id}_B \circ \sigma \cong \sigma$ .

# Strategies as discrete fibrations

[Winskel 2011-13]

**Def.** A strategy  $\sigma : A \dashrightarrow B$  is a pre-strategy such that  $\sigma \circ \text{id}_A \cong \sigma$  and  $\text{id}_B \circ \sigma \cong \sigma$ .

## Equivalent characterization.

$\sigma$  is a strategy if and only if

$\mathcal{C}(S) \rightarrow \mathcal{C}(A^\perp \parallel B)$  has unique lifting properties:

# Strategies as discrete fibrations

[Winskel 2011-13]

**Def.** A strategy  $\sigma : A \dashrightarrow B$  is a pre-strategy such that  $\sigma \circ \text{id}_A \cong \sigma$  and  $\text{id}_B \circ \sigma \cong \sigma$ .

## Equivalent characterization.

$\sigma$  is a strategy if and only if

$\mathcal{C}(S) \rightarrow \mathcal{C}(A^\perp \parallel B)$  has unique lifting properties:



# Strategies as discrete fibrations

[Winskel 2011-13]

**Def.** A strategy  $\sigma : A \dashrightarrow B$  is a pre-strategy such that  $\sigma \circ \text{id}_A \cong \sigma$  and  $\text{id}_B \circ \sigma \cong \sigma$ .

## Equivalent characterization.

$\sigma$  is a strategy if and only if

$\mathcal{C}(S) \rightarrow \mathcal{C}(A^\perp \parallel B)$  has unique lifting properties:

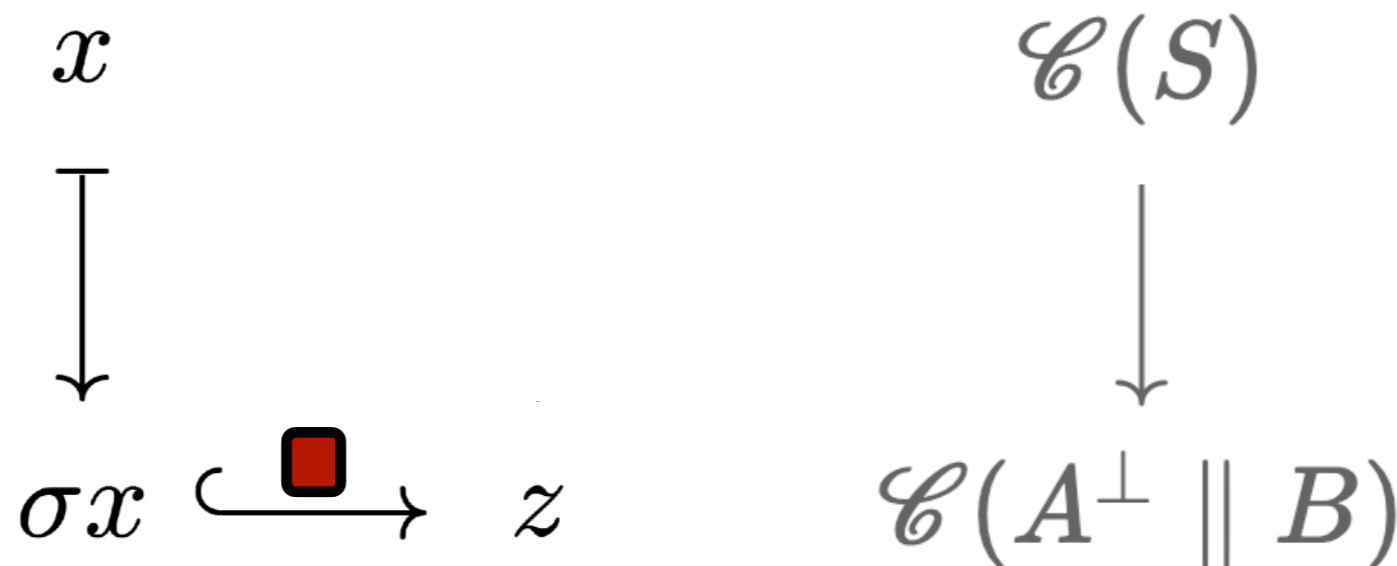

# Strategies as discrete fibrations

[Winskel 2011-13]

**Def.** A strategy  $\sigma : A \dashrightarrow B$  is a pre-strategy such that  $\sigma \circ \text{id}_A \cong \sigma$  and  $\text{id}_B \circ \sigma \cong \sigma$ .

## Equivalent characterization.

$\sigma$  is a strategy if and only if

$\mathcal{C}(S) \rightarrow \mathcal{C}(A^\perp \parallel B)$  has unique lifting properties:

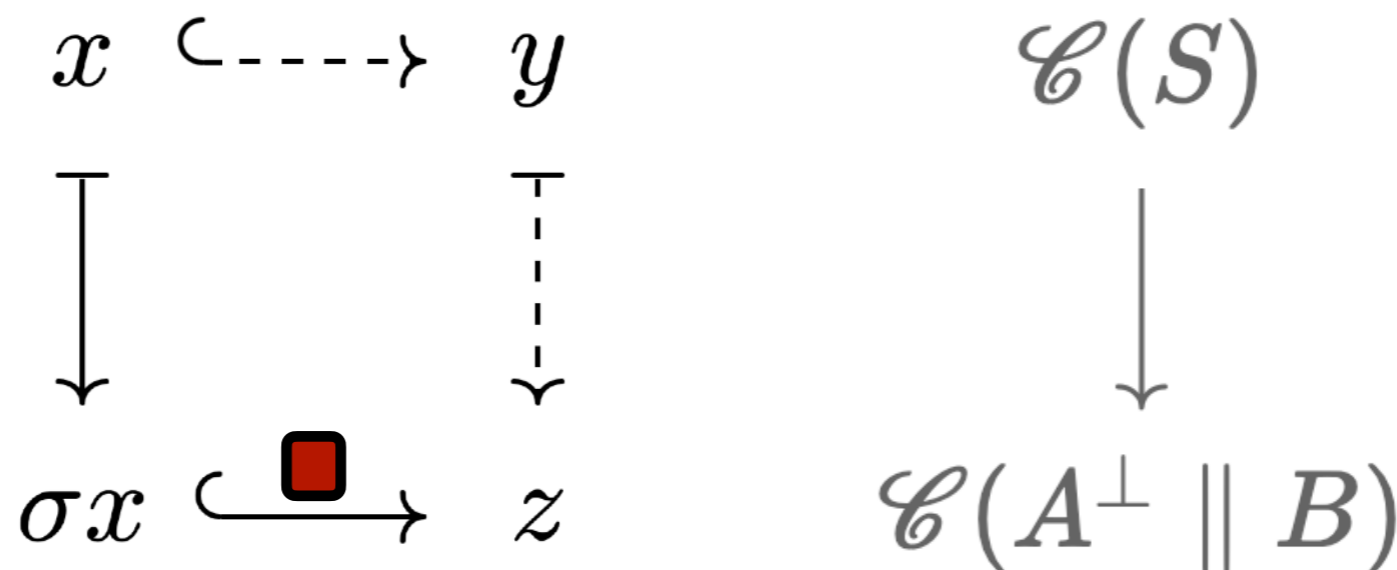

# Strategies as discrete fibrations

[Winskel 2011-13]

**Def.** A strategy  $\sigma : A \dashrightarrow B$  is a pre-strategy such that  $\sigma \circ \text{id}_A \cong \sigma$  and  $\text{id}_B \circ \sigma \cong \sigma$ .

## Equivalent characterization.

$\sigma$  is a strategy if and only if

$\mathcal{C}(S) \rightarrow \mathcal{C}(A^\perp \parallel B)$  has unique lifting properties:

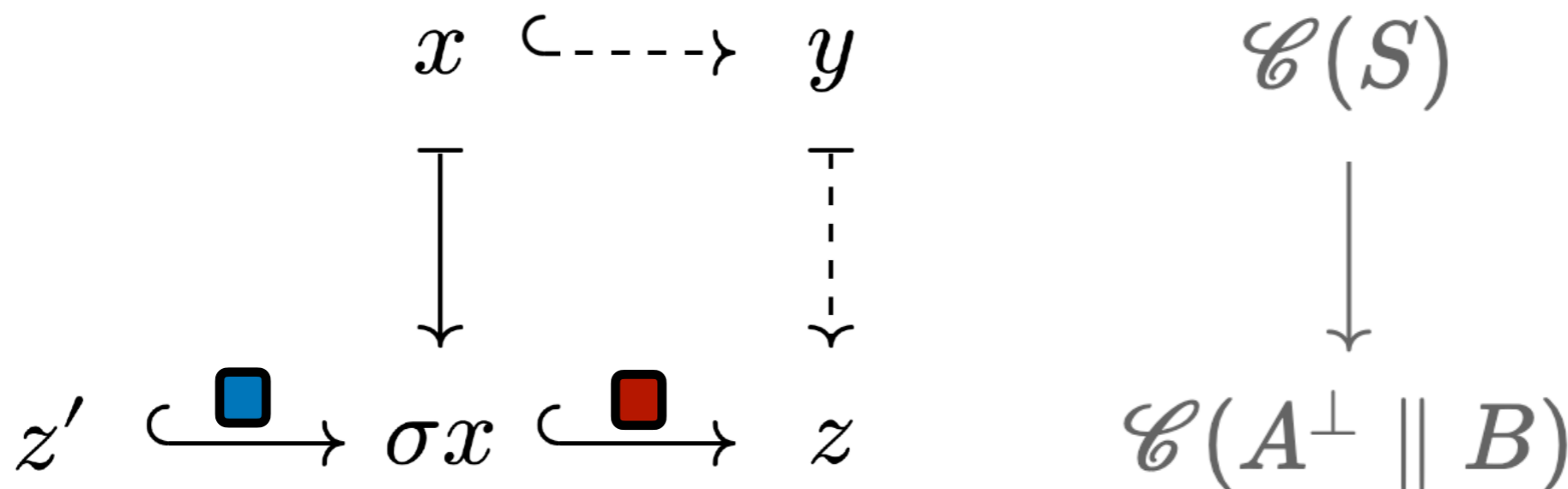

# Strategies as discrete fibrations

[Winskel 2011-13]

**Def.** A strategy  $\sigma : A \dashrightarrow B$  is a pre-strategy such that  $\sigma \circ \text{id}_A \cong \sigma$  and  $\text{id}_B \circ \sigma \cong \sigma$ .

## Equivalent characterization.

$\sigma$  is a strategy if and only if

$\mathcal{C}(S) \rightarrow \mathcal{C}(A^\perp \parallel B)$  has unique lifting properties:

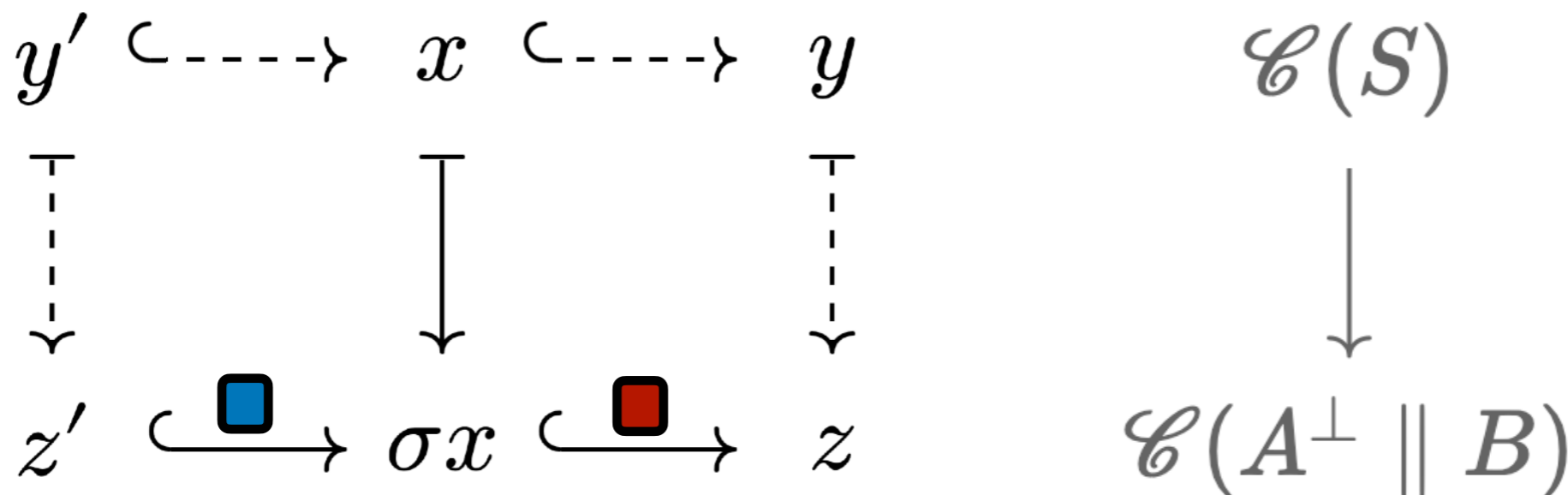

# Strategies as discrete fibrations

[Winskel 2011-13]

**Def.** A strategy  $\sigma : A \dashv\vdash B$  is a pre-strategy such that  $\sigma \circ \text{id}_A \cong \sigma$  and  $\text{id}_B \circ \sigma \cong \sigma$ .

## Equivalent characterization.

$\sigma$  is a strategy if and only if

$\mathcal{C}(S) \rightarrow \mathcal{C}(A^\perp \parallel B)$  is a discrete fibration for  $\sqsubseteq$  ■  
and a discrete op-fibration for  $\sqsubseteq$  ■.

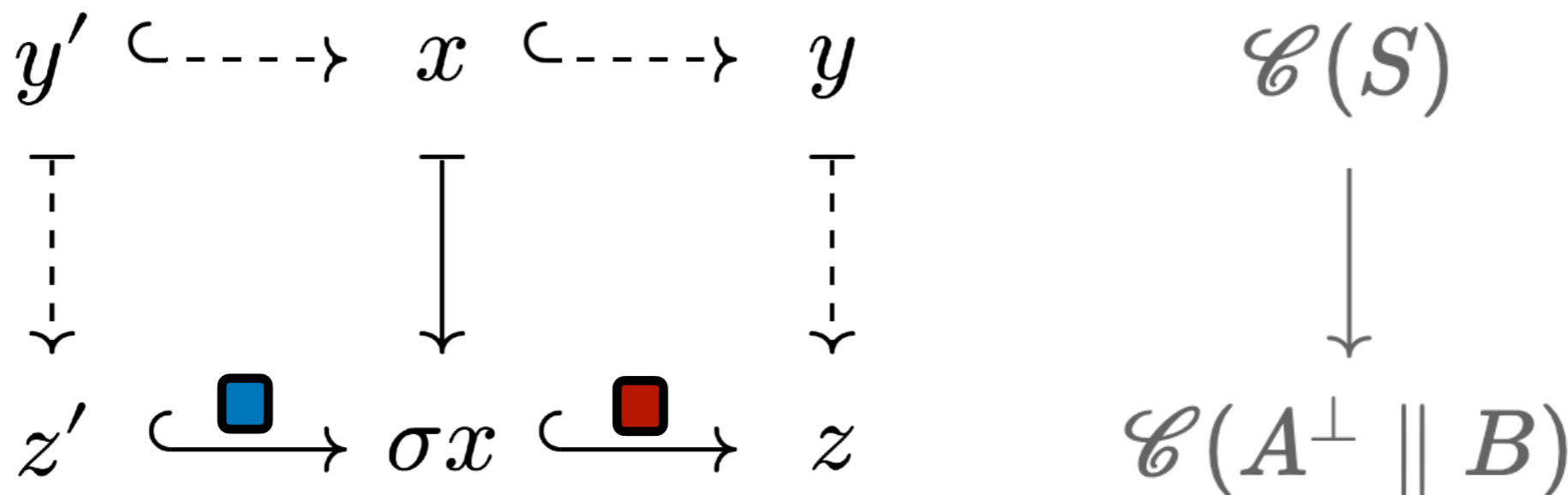

# Strategies as discrete fibrations

[Winskel 2011-13]

**Def.** A strategy  $\sigma : A \dashv\vdash B$  is a pre-strategy such that  $\sigma \circ \text{id}_A \cong \sigma$  and  $\text{id}_B \circ \sigma \cong \sigma$ .

## Equivalent characterization.

$\sigma$  is a strategy if and only if

$\mathcal{C}(S) \rightarrow \mathcal{C}(A^\perp \parallel B)$  is a discrete fibration for  $\supseteq^{\blacksquare} \cdot \subseteq^{\blacksquare}$ .

(the "Scott order")

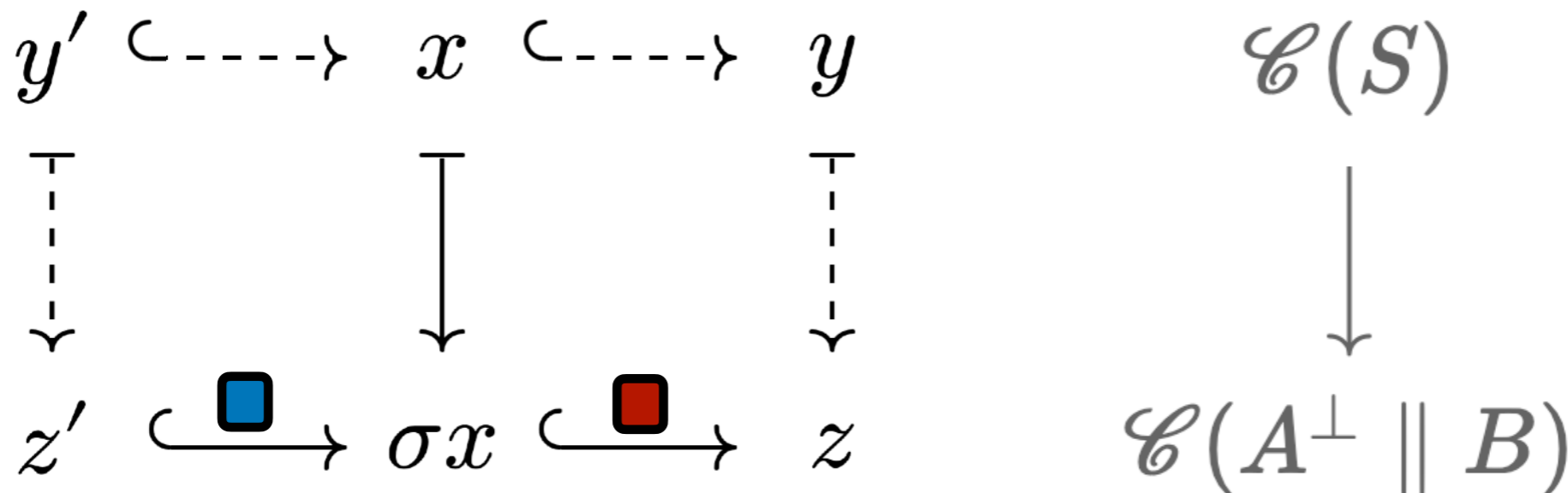

# Strategies as discrete fibrations

**Def.** A strategy  $\sigma : A \dashrightarrow B$  is a pre-strategy such that  $\sigma \circ \text{id}_A \cong \sigma$  and  $\text{id}_B \circ \sigma \cong \sigma$ .

## Equivalent characterization.

$\sigma$  is a strategy if and only if

$\mathcal{C}(S) \rightarrow \mathcal{C}(A^\perp \parallel B)$  is a discrete fibration for  $\supseteq^{\blacksquare}$  ·  $\subseteq^{\blacksquare}$ .

This paper: **games with symmetry and strategies as Street fibrations.**

*Example of a pre-strategy which is not a strategy:*

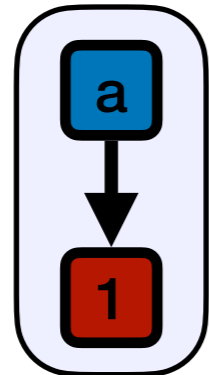
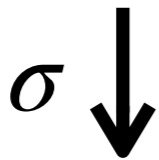
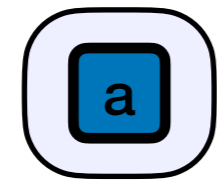

*A*

*Example of a pre-strategy which is not a strategy:*

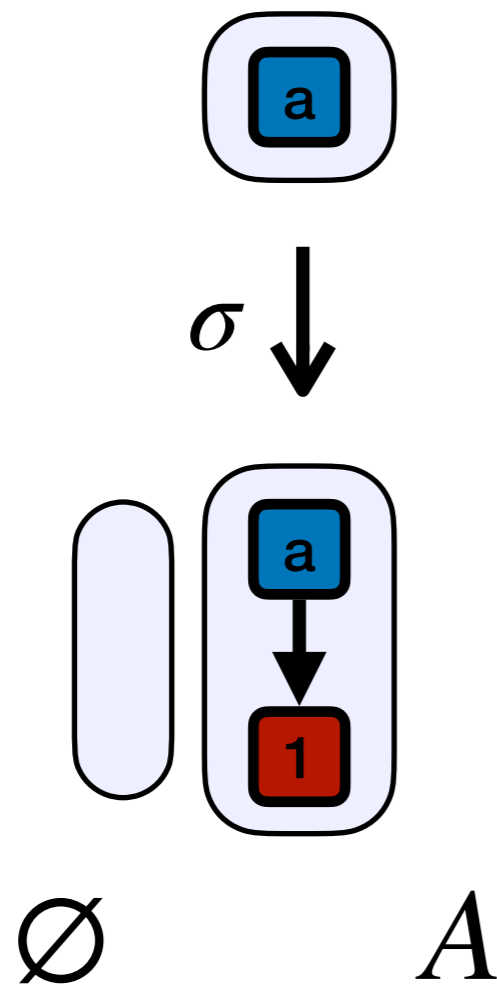

*Example of a pre-strategy which is not a strategy:*

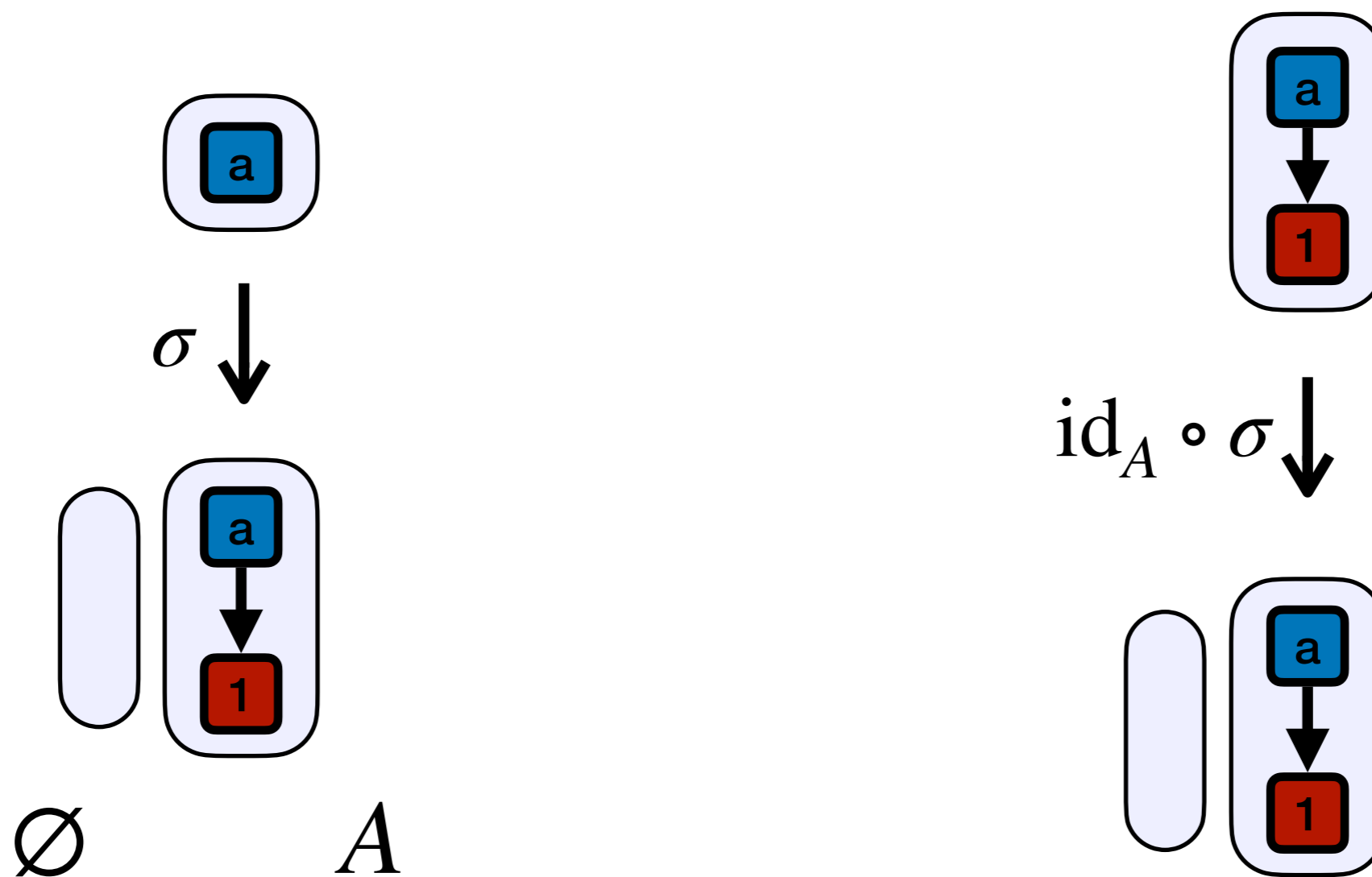

*Example of a pre-strategy which is not a strategy:*

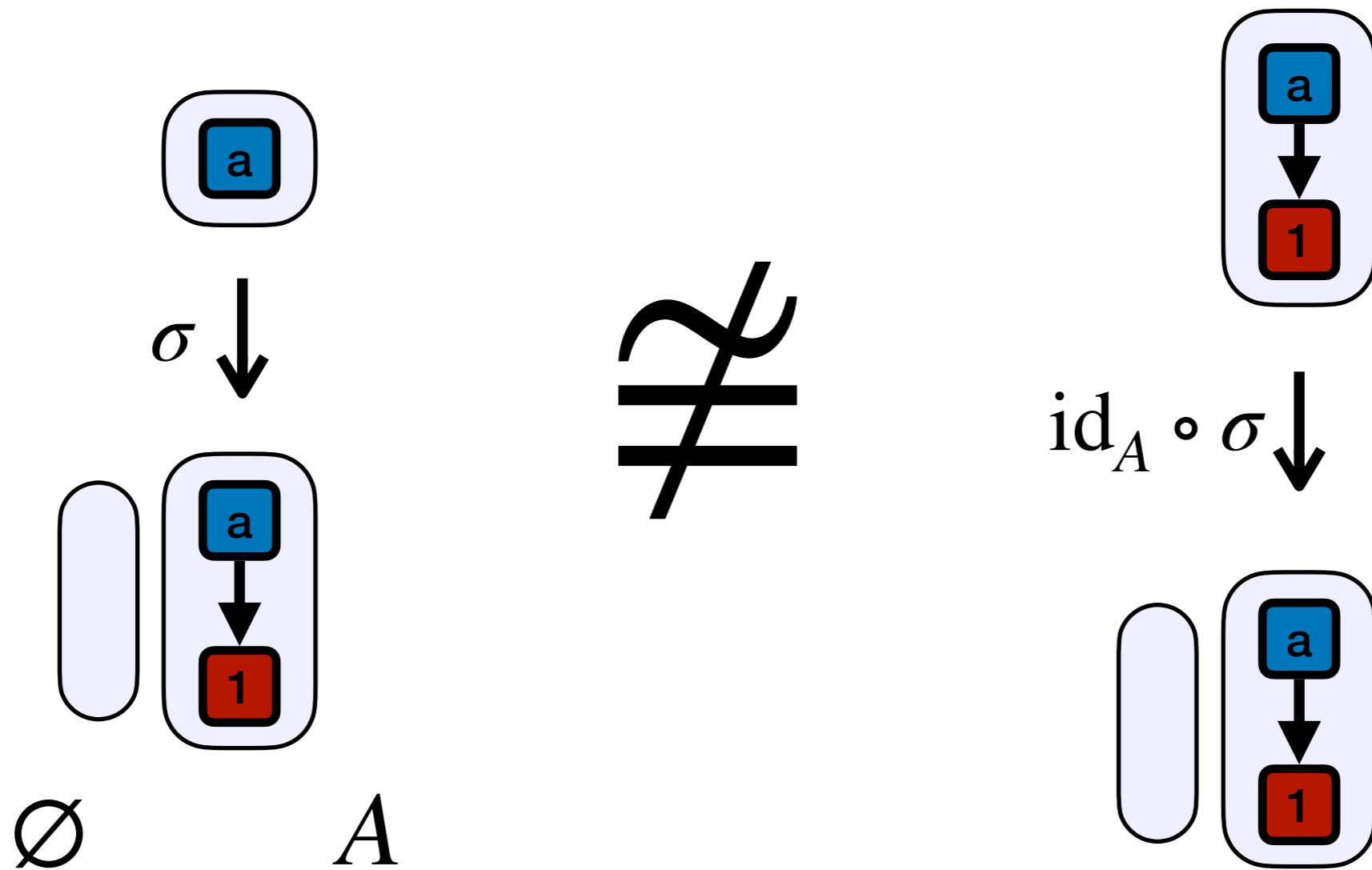

# Rest of the talk.

- I. Games and strategies with symmetry
- II. Strategies as Street fibrations
- III. Other results

**An event structure with symmetry** is an  
event structure  $E$  + groupoid structure on  $\mathcal{C}(E)$  + axioms  
*[Winskel 2007]*

An **event structure with symmetry** is an  
event structure  $E$  + groupoid structure on  $\mathcal{C}(E)$  + axioms  
*[Winskel 2007]*

# Games and strategies with symmetry

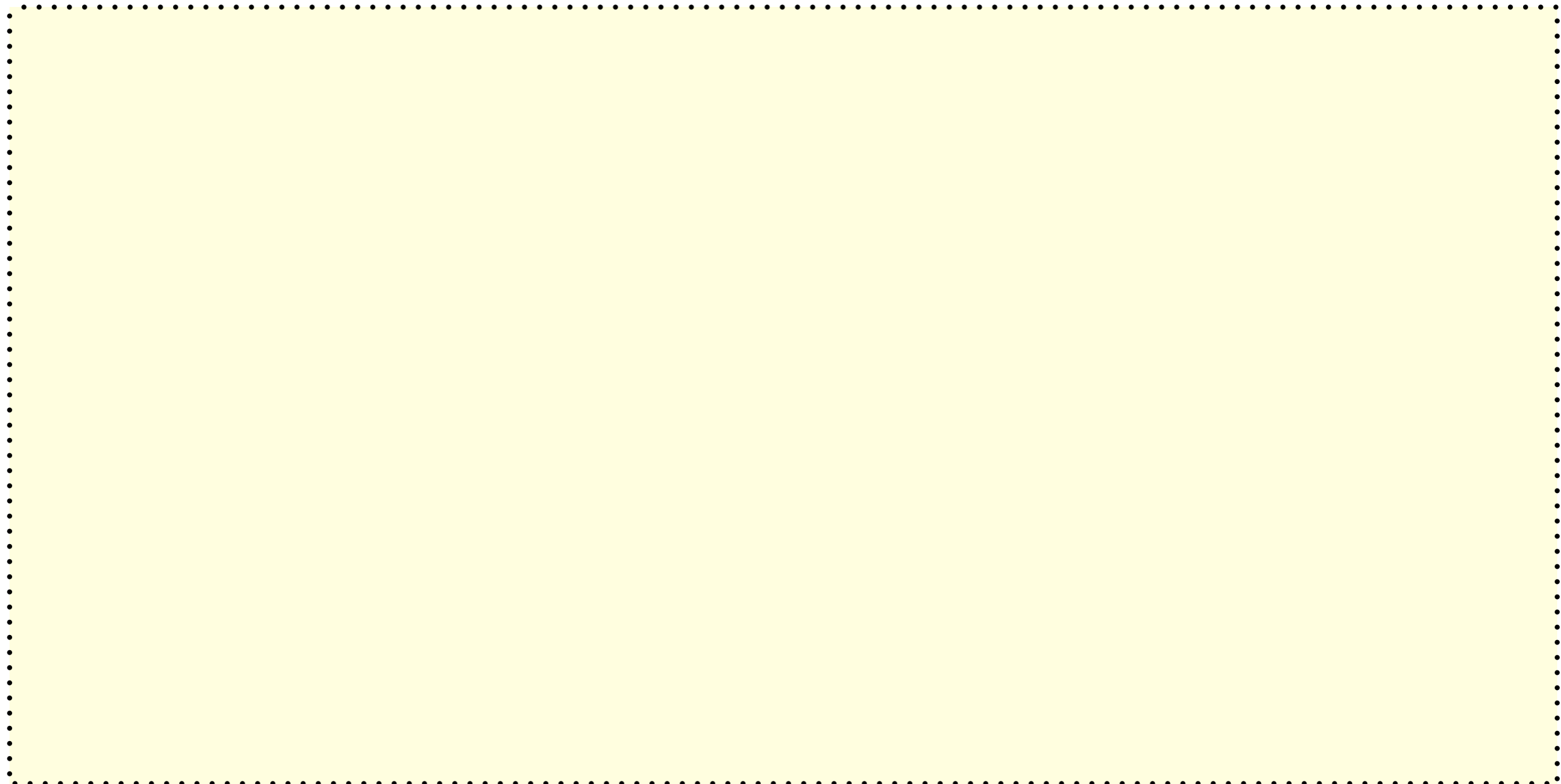

An **event structure with symmetry** is an  
event structure  $E$  + groupoid structure on  $\mathcal{C}(E)$  + axioms  
*[Winskel 2007]*

# Games and strategies with symmetry



An **event structure with symmetry** is an event structure  $E$  + groupoid structure on  $\mathcal{C}(E)$  + axioms  
*[Winskel 2007]*

# Games and strategies with symmetry

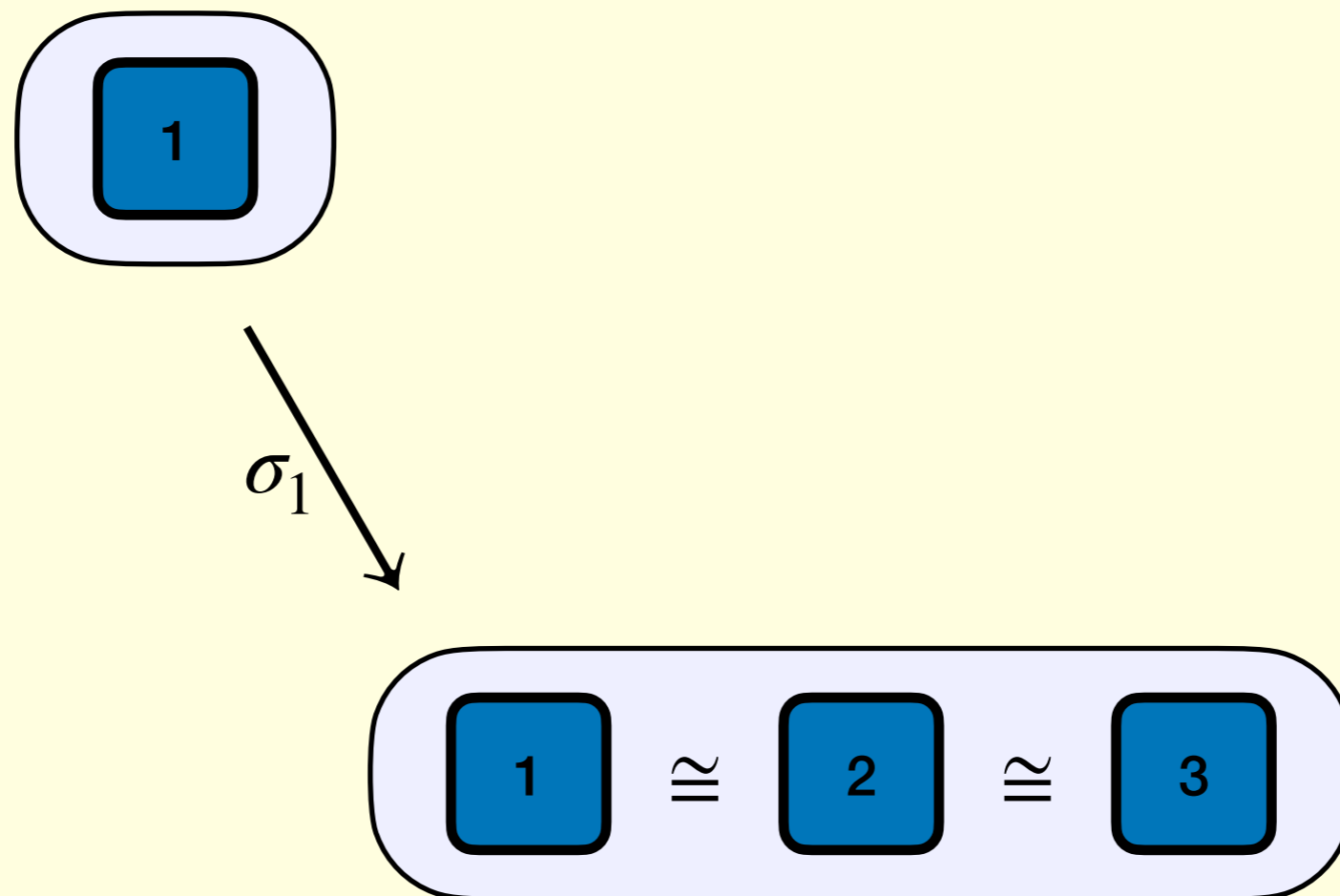

An **event structure with symmetry** is an event structure  $E$  + groupoid structure on  $\mathcal{C}(E)$  + axioms  
*[Winskel 2007]*

# Games and strategies with symmetry

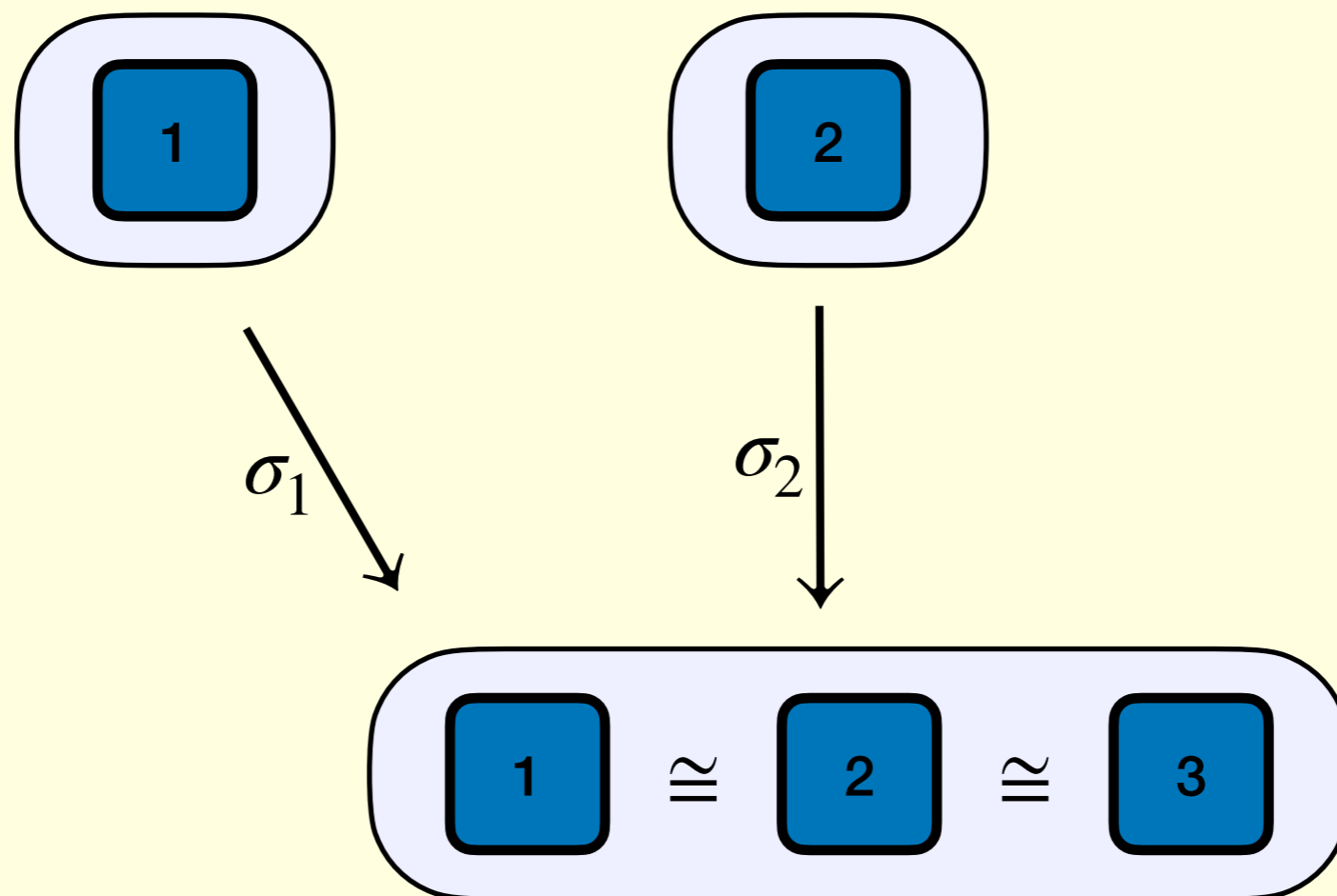

An **event structure with symmetry** is an event structure  $E$  + groupoid structure on  $\mathcal{C}(E)$  + axioms  
*[Winskel 2007]*

# Games and strategies with symmetry

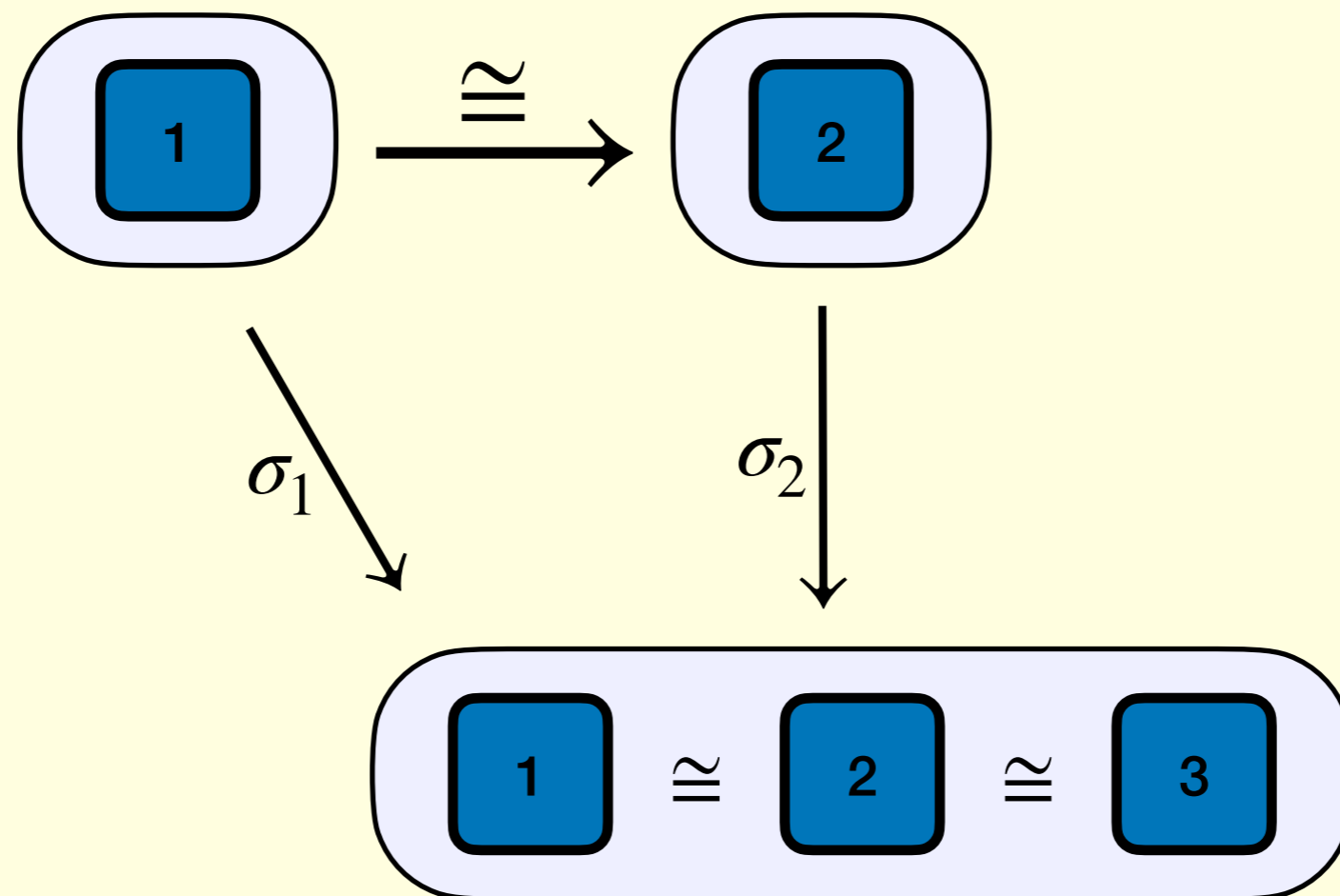

An **event structure with symmetry** is an event structure  $E$  + groupoid structure on  $\mathcal{C}(E)$  + axioms  
*[Winskel 2007]*

# Games and strategies with symmetry

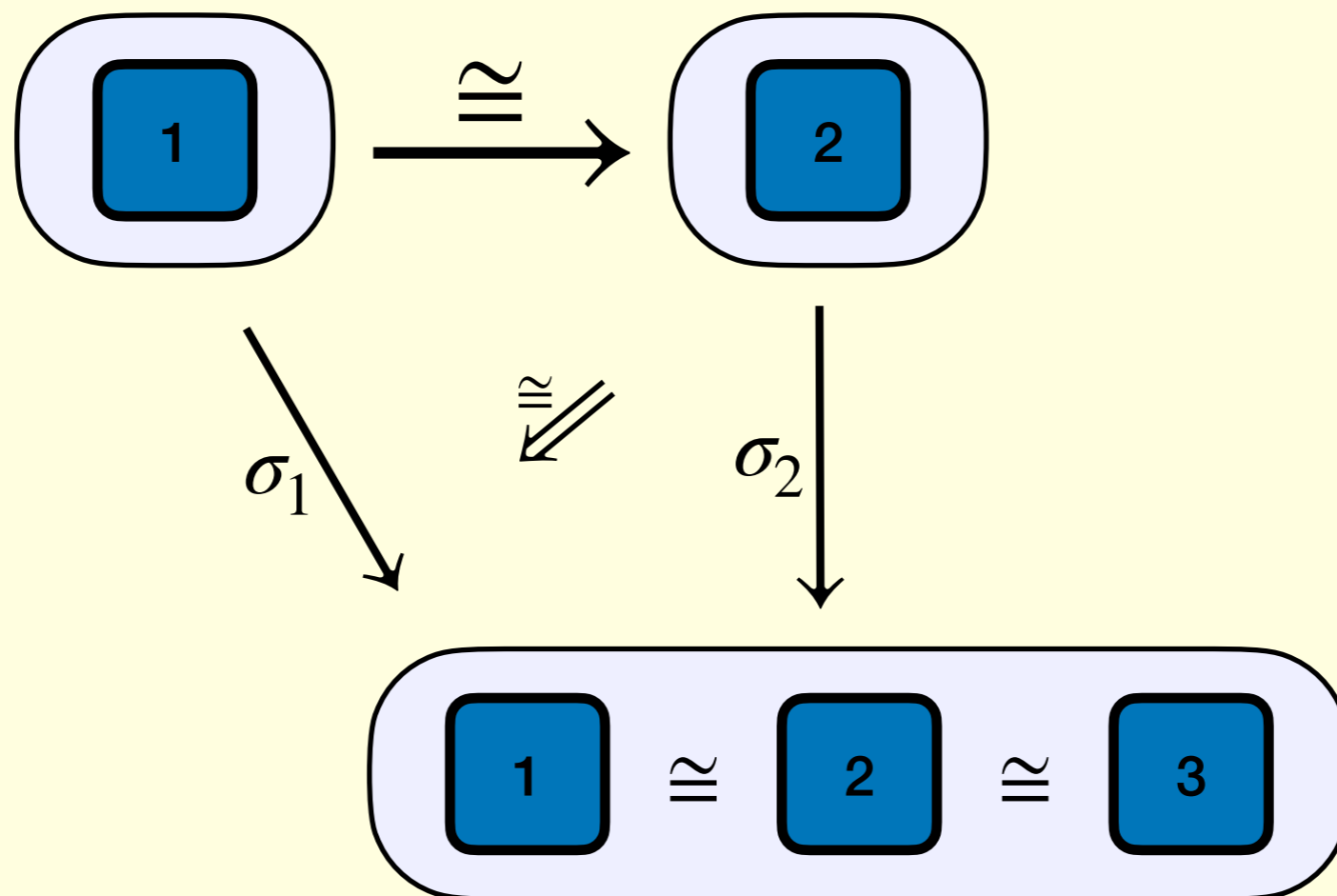

An **event structure with symmetry** is an event structure  $E$  + groupoid structure on  $\mathcal{C}(E)$  + axioms  
*[Winskel 2007]*

# Games and strategies with symmetry

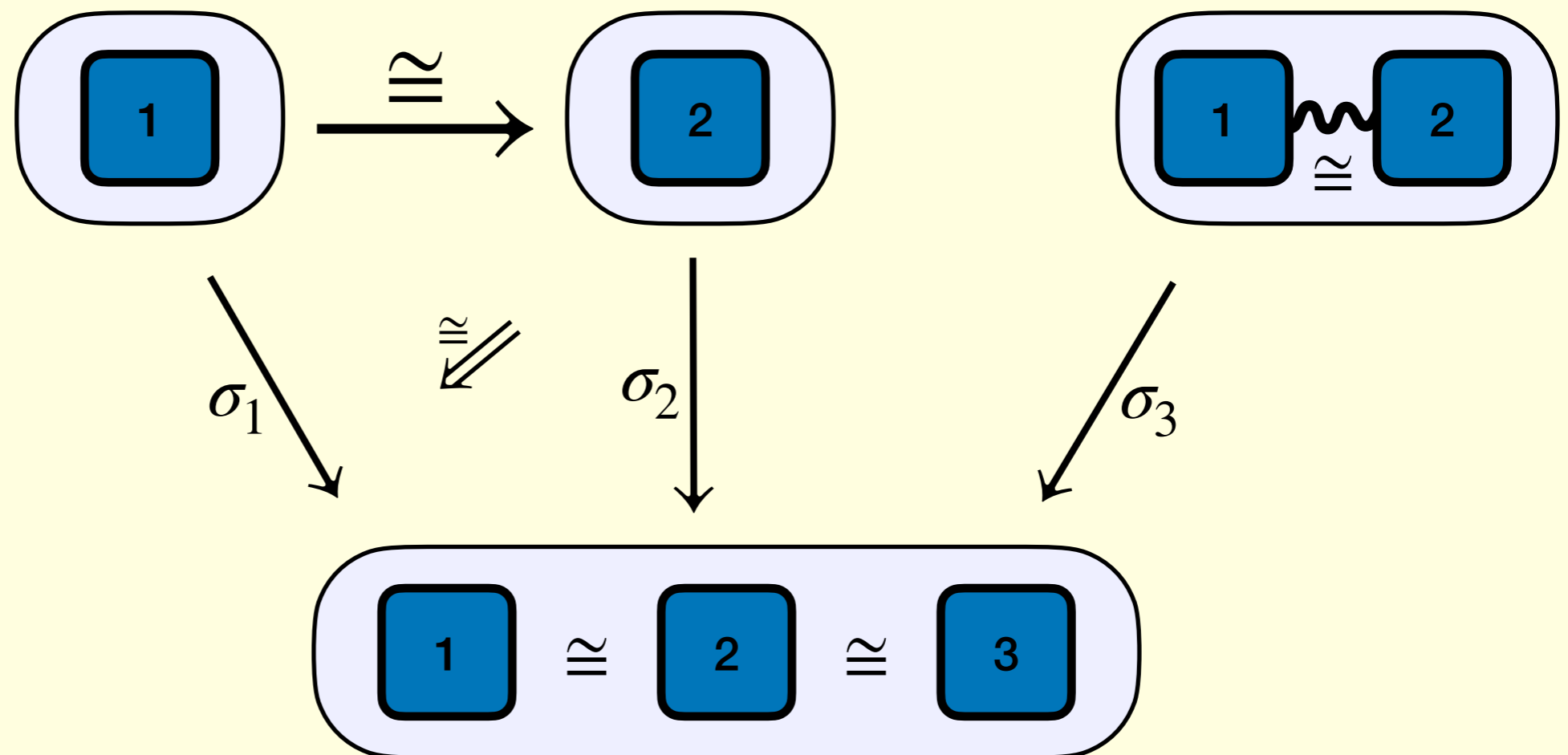

An **event structure with symmetry** is an event structure  $E$  + groupoid structure on  $\mathcal{C}(E)$  + axioms  
*[Winskel 2007]*

# Games and strategies with symmetry

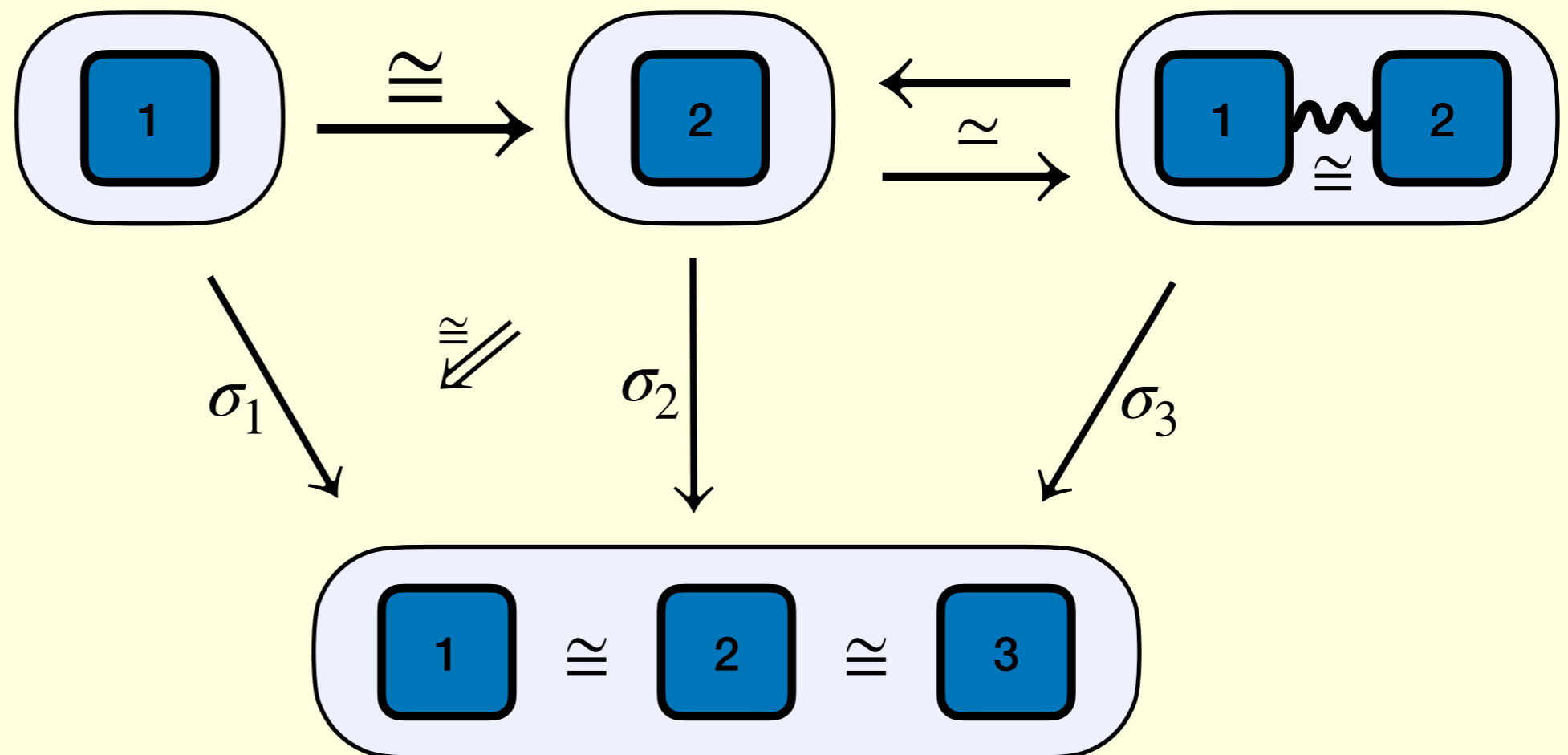

An **event structure with symmetry** is an event structure  $E$  + groupoid structure on  $\mathcal{C}(E)$  + axioms  
*[Winskel 2007]*

# Games and strategies with symmetry

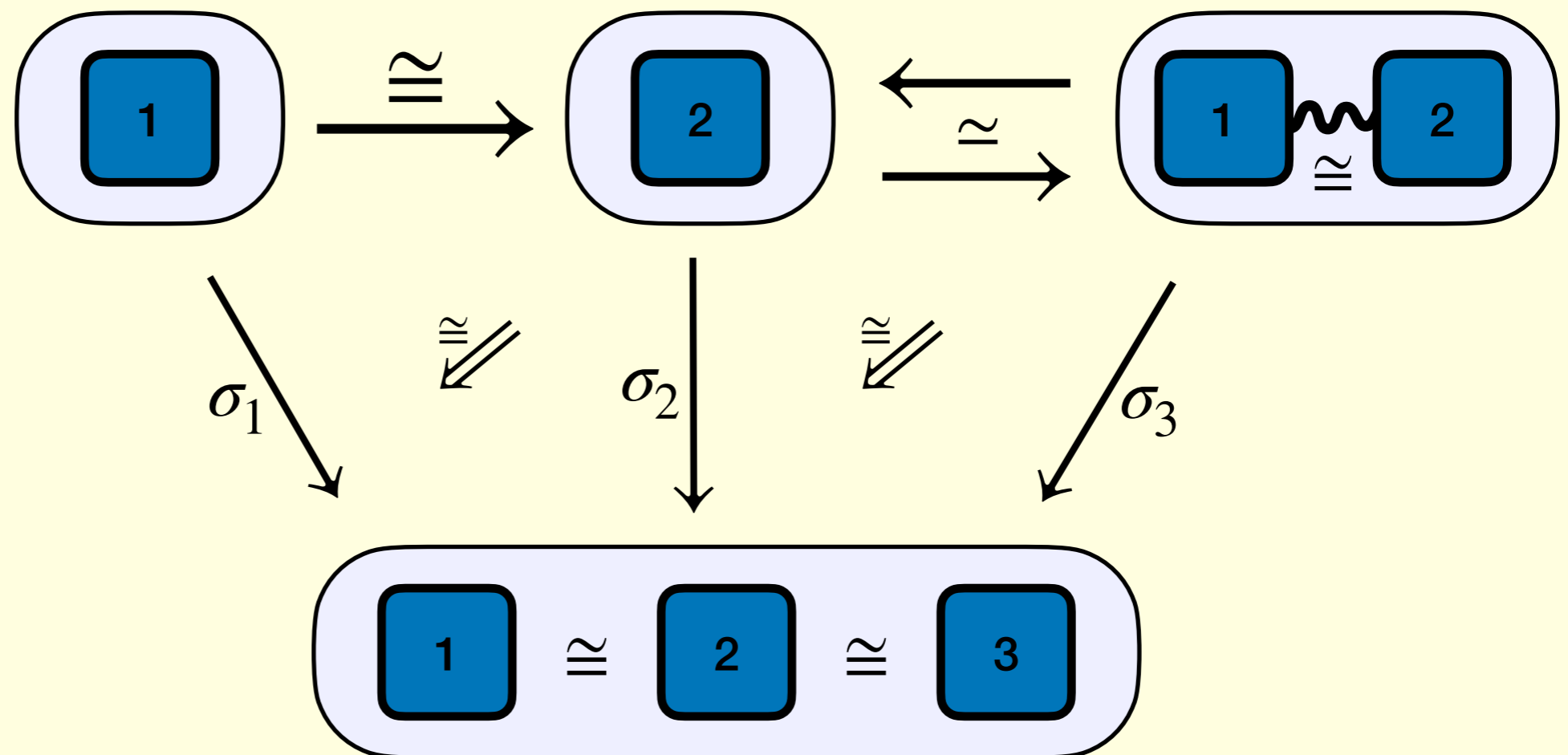

# Notions of equivalence

# Notions of equivalence

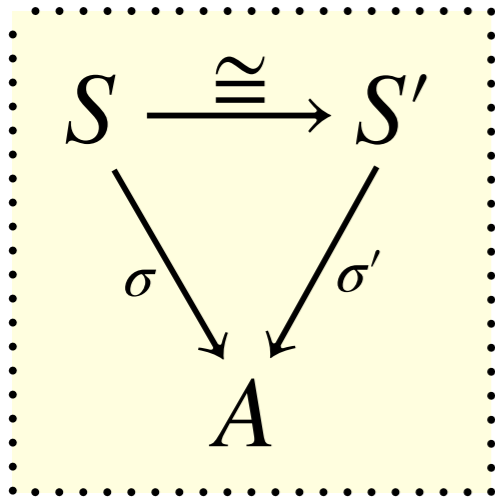

# Notions of equivalence

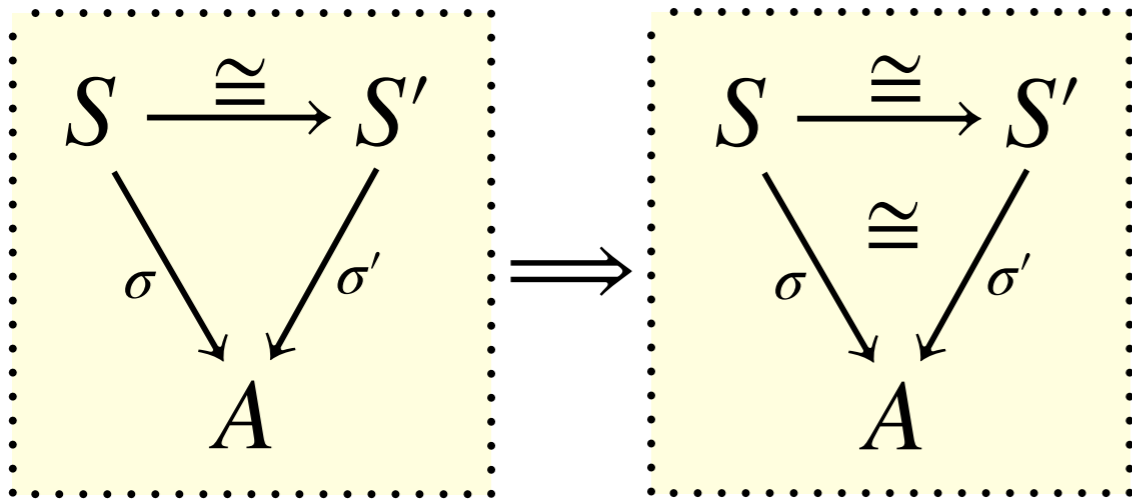

# Notions of equivalence

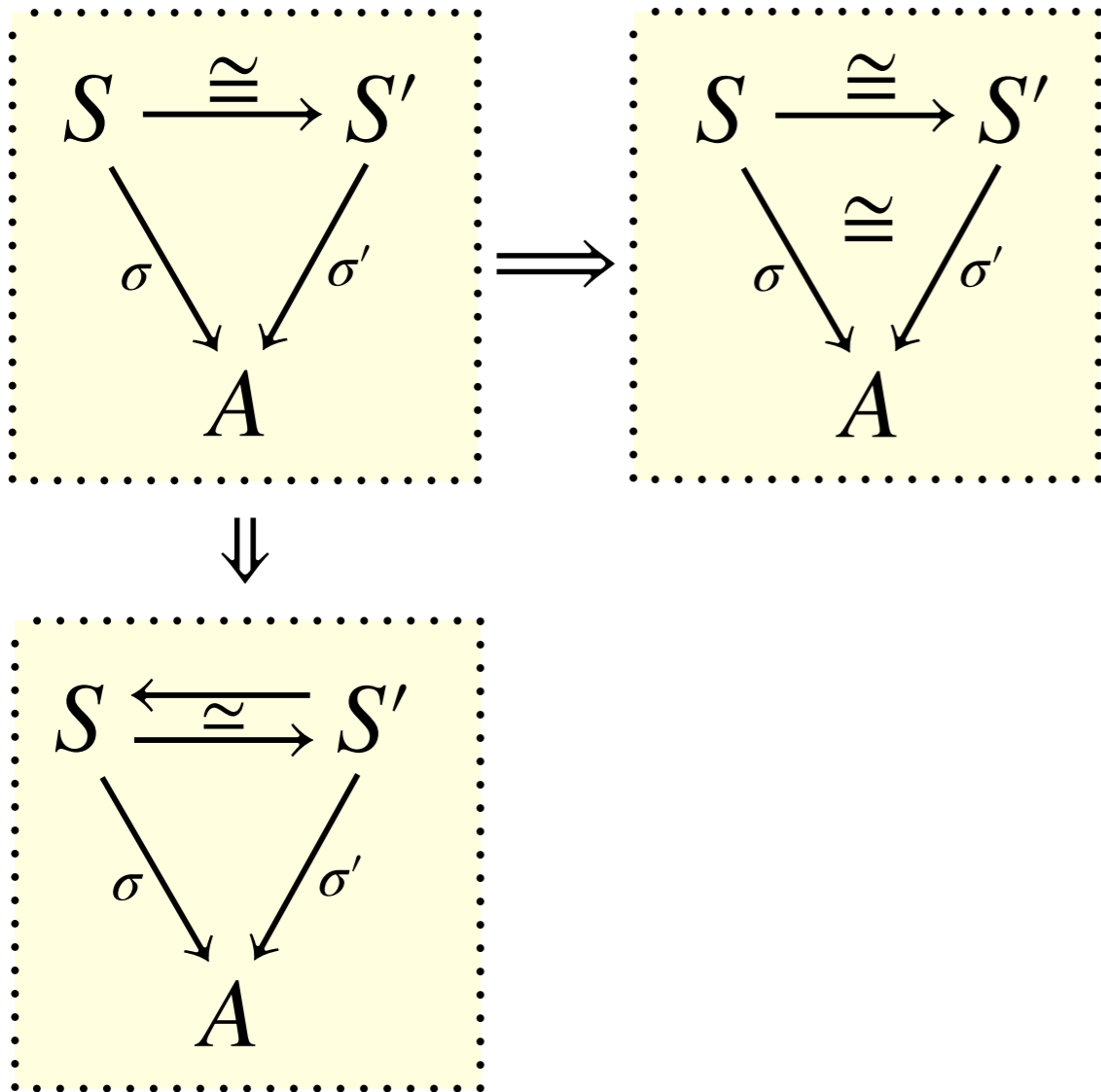

# Notions of equivalence

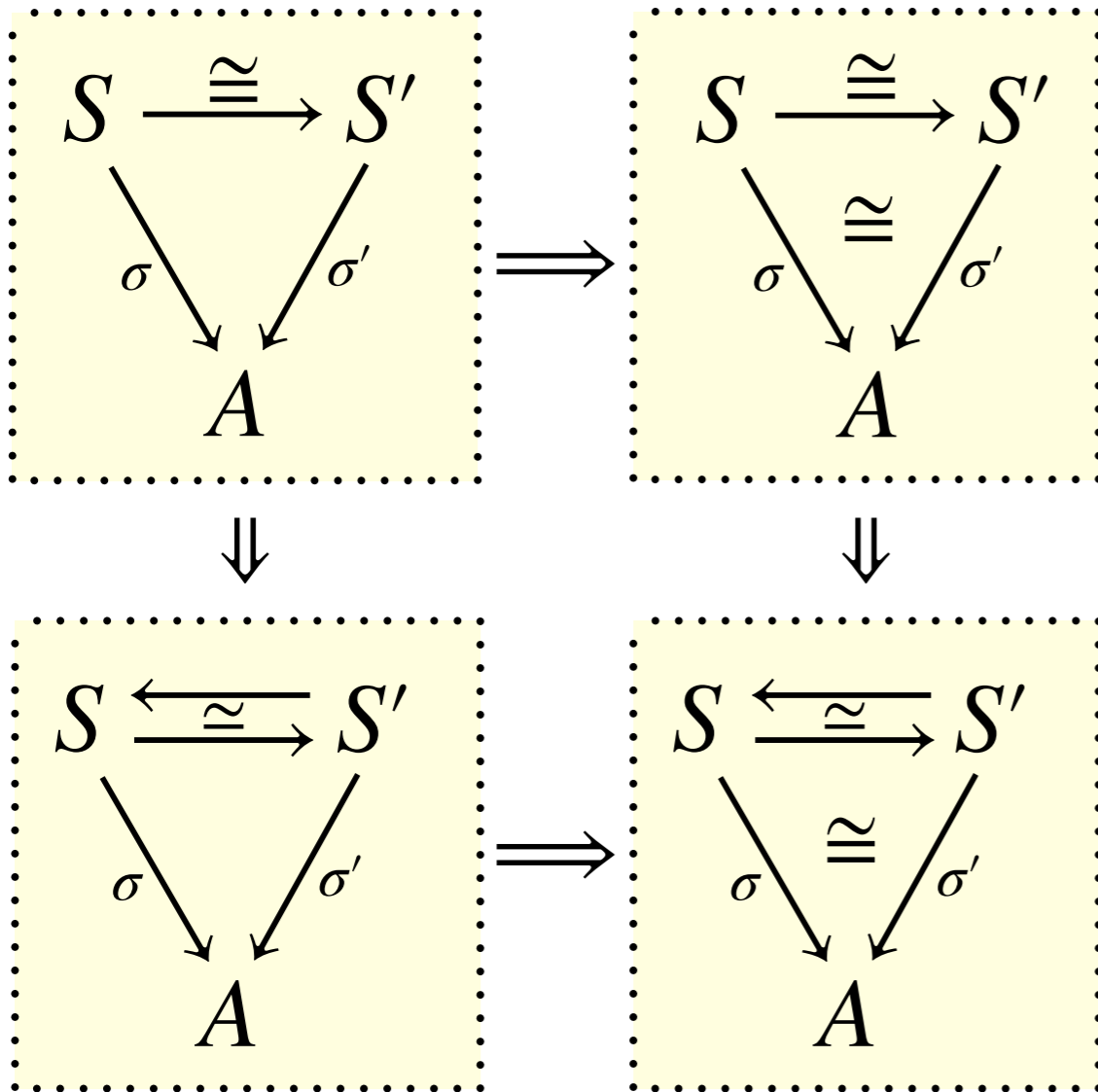

# Notions of equivalence

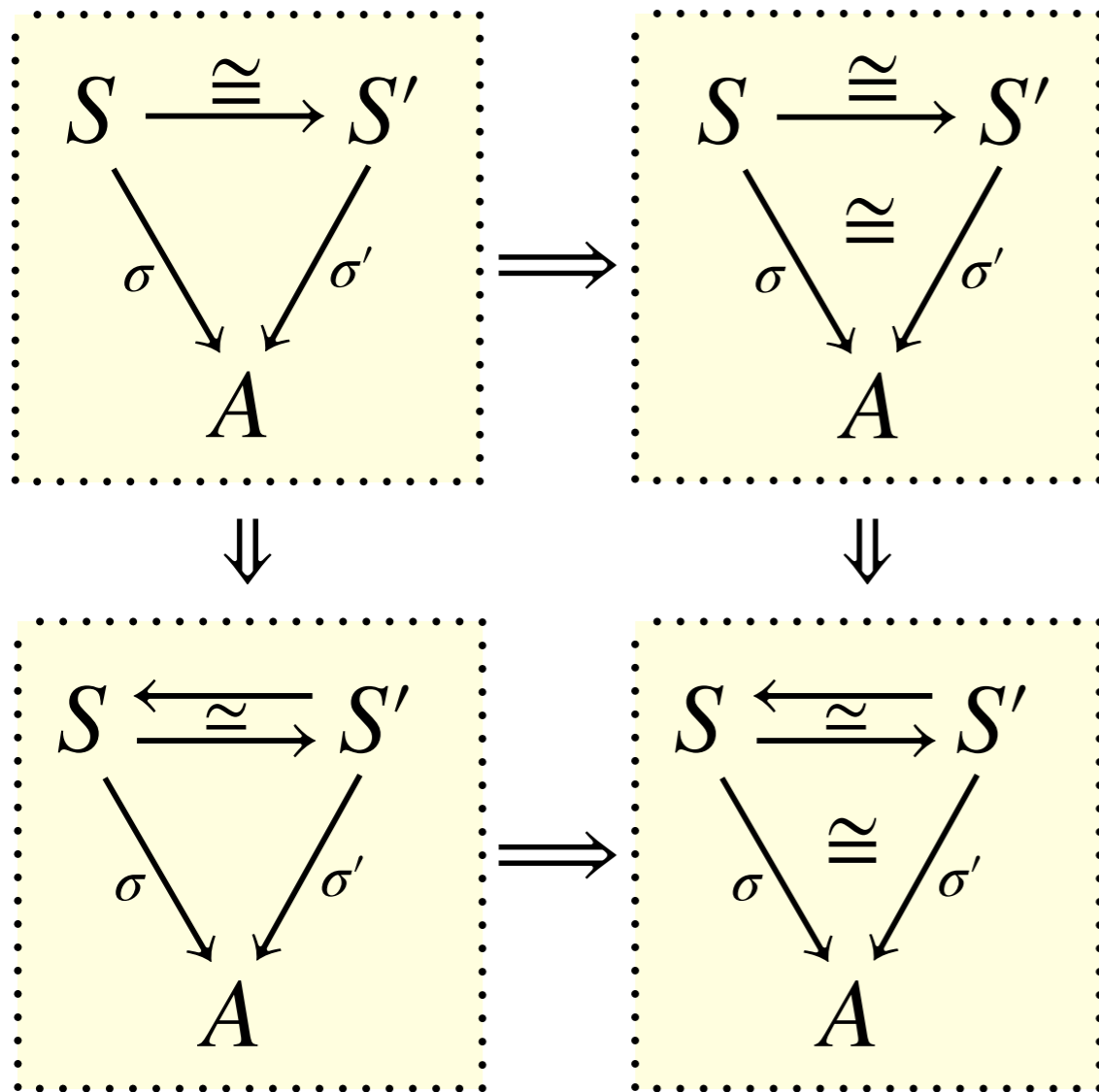

Choice of  $\sim$  (and  $\text{id}$ ,  $\circ$ )  
determines a model:

**Def.** A strategy  $\sigma : A \dashrightarrow B$  is a pre-strategy such that  $\sigma \circ \text{id}_A \sim \sigma$  and  $\text{id}_B \circ \sigma \sim \sigma$ .

# Notions of equivalence

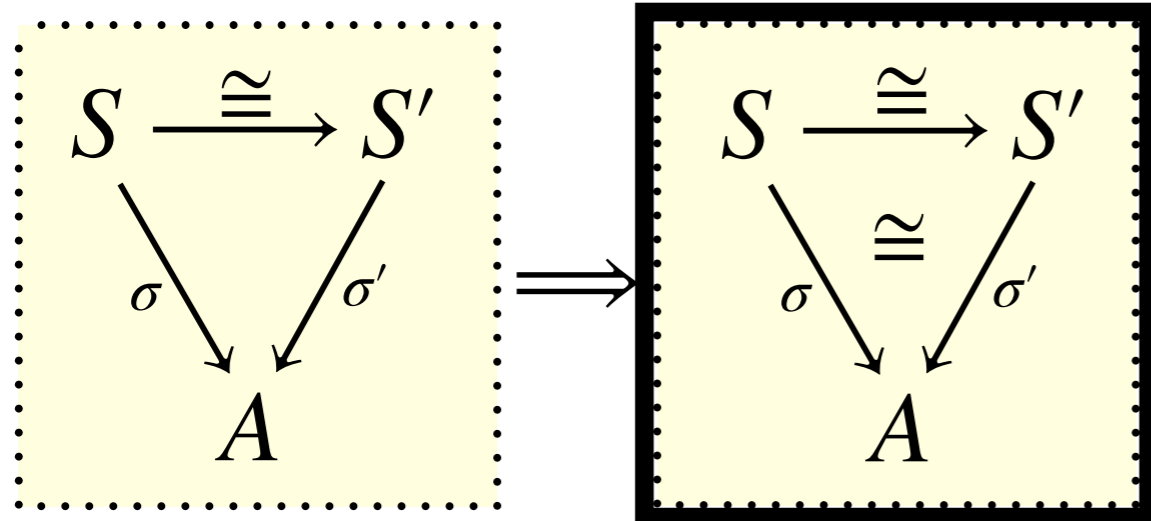

*Thin concurrent games*  
 [Clairambault and others, 2015–now]

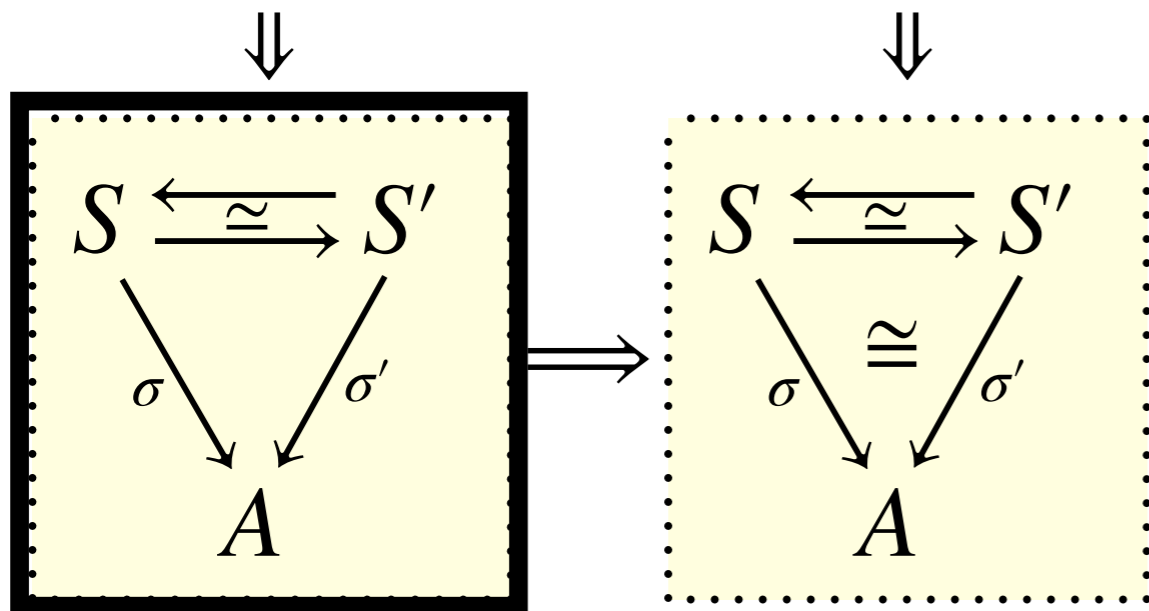

[CCW 2014]

# Notions of equivalence

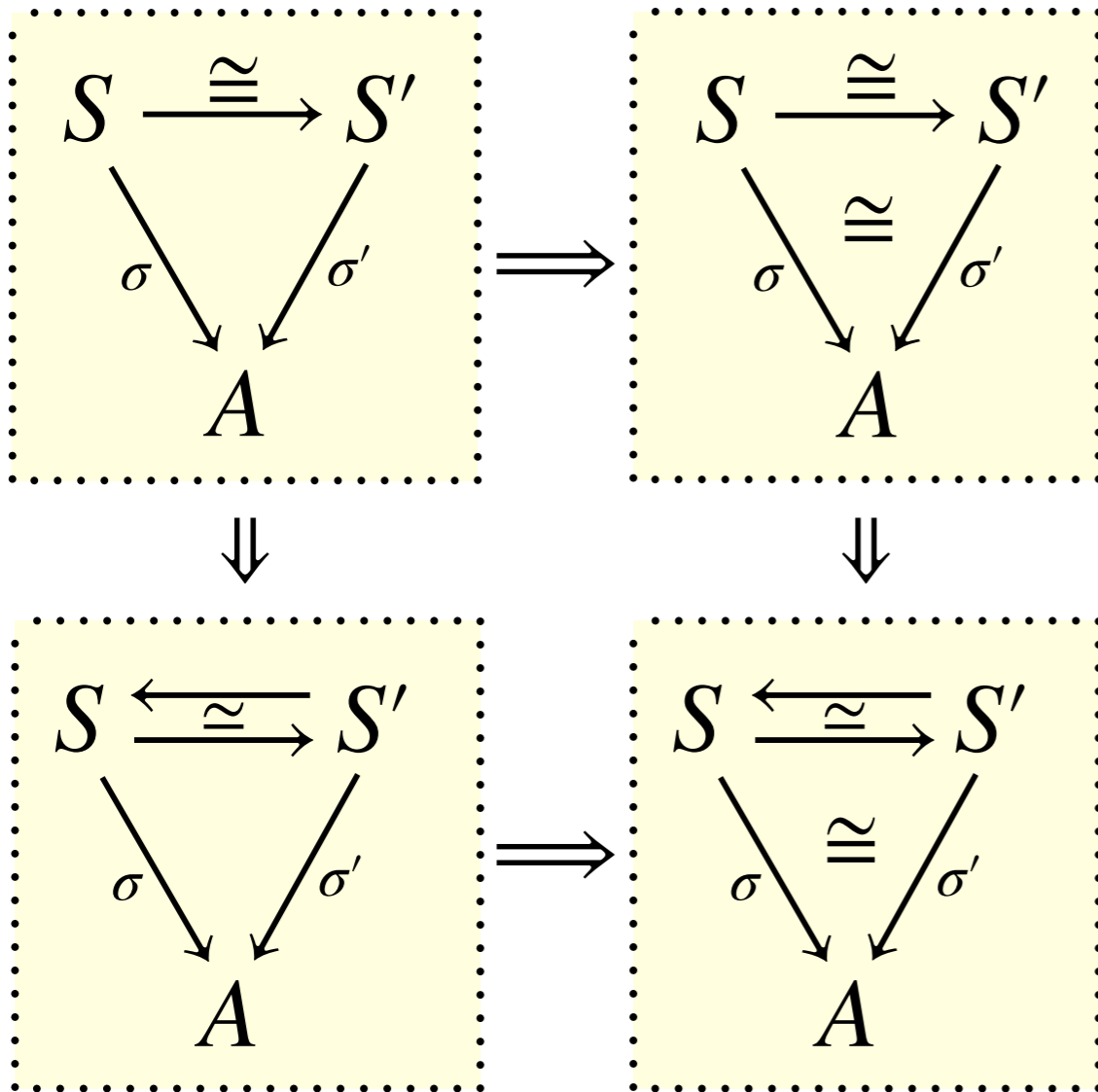

# Notions of equivalence

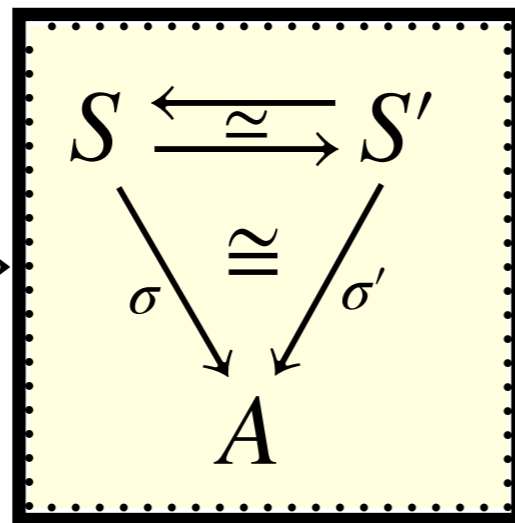
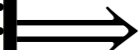
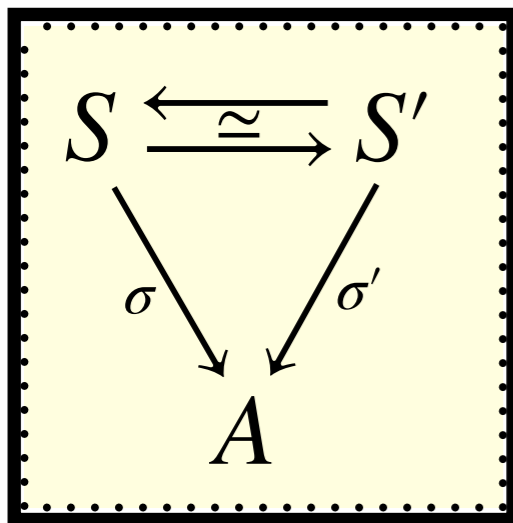
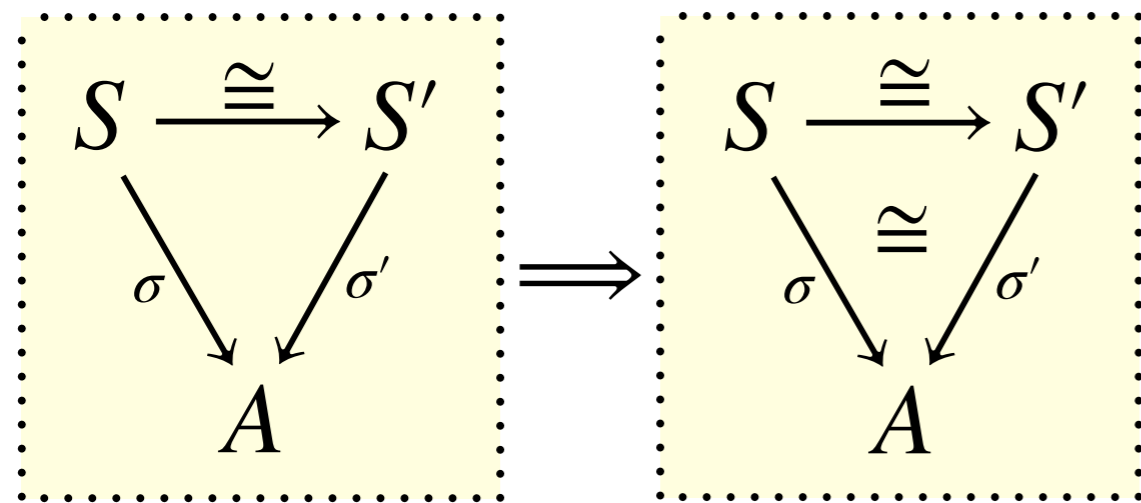

*Strong  
strategies*

*Weak  
strategies*

# Notions of equivalence

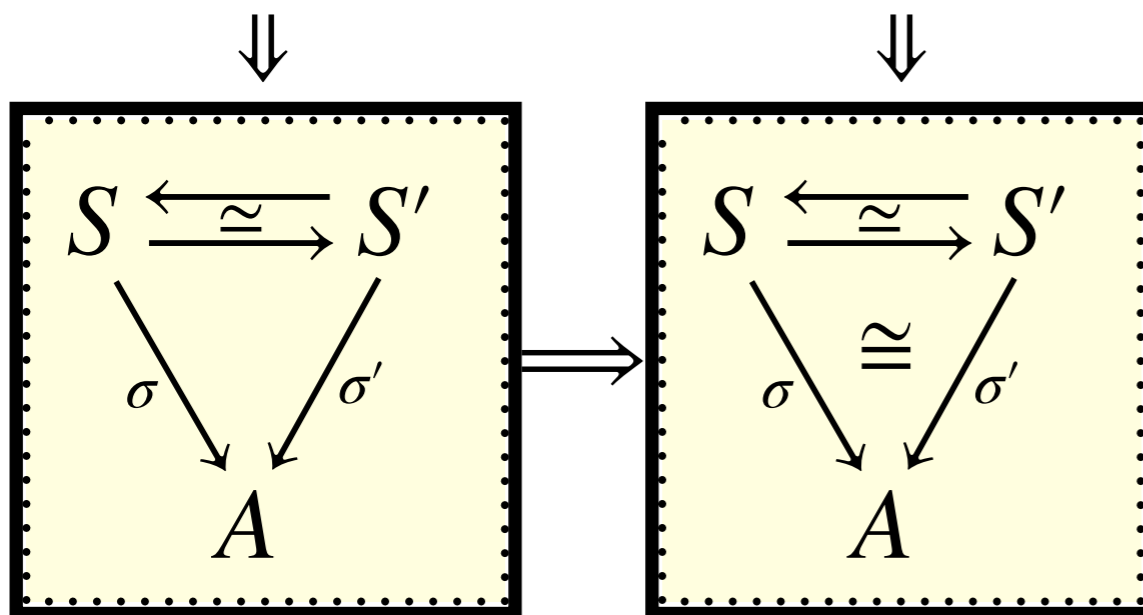
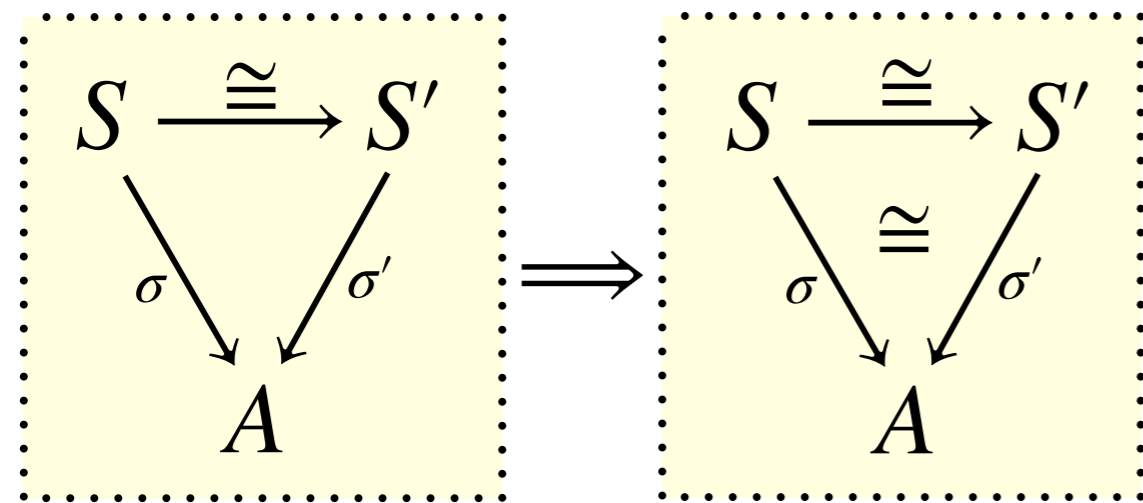

*Strong  
strategies*

*Weak  
strategies*

We characterized these classes of strategies in terms of lifting properties.

# Lifting properties

A functor  $p : \mathbb{C} \rightarrow \mathbb{D}$  is a

- a **discrete fibration** if it has **unique** lifts
- a **Grothendieck fibration** if it has **cartesian** lifts
- a **Street fibration** if it has **cartesian *pseudo-lifts***

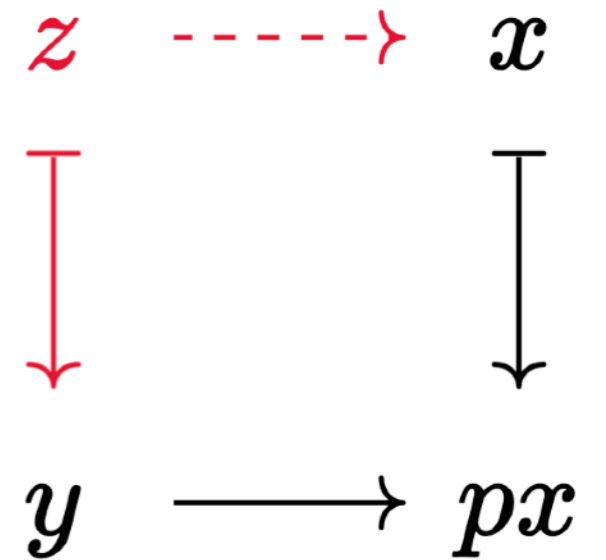

# Lifting properties

A functor  $p : \mathbb{C} \rightarrow \mathbb{D}$  is a

- a **discrete fibration** if it has **unique** lifts
- a **Grothendieck fibration** if it has **cartesian** lifts
- a **Street fibration** if it has **cartesian *pseudo-lifts***

$$\begin{array}{ccc} z & \overset{\text{---}}{\dashrightarrow} & x \\ \downarrow & & \downarrow \\ w & \overset{\cong}{\dashrightarrow} & y \longrightarrow px \end{array}$$

# Lifting properties

A functor  $p : \mathbb{C} \rightarrow \mathbb{D}$  is a

- a **discrete fibration** if it has **unique** lifts
- a **Grothendieck fibration** if it has **cartesian** lifts
- a **Street fibration** if it has **cartesian *pseudo-lifts***

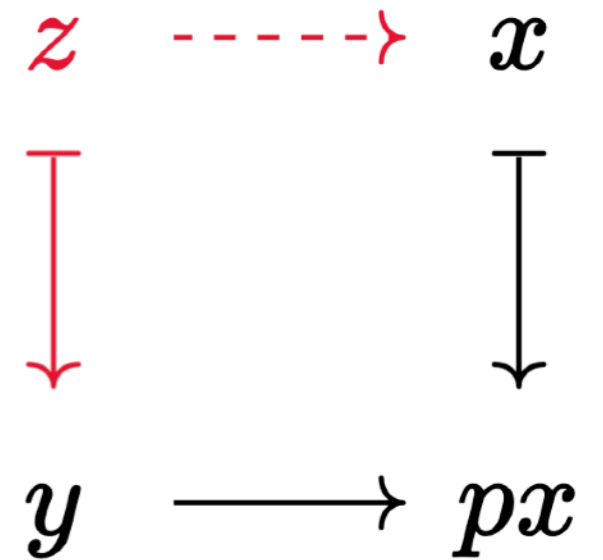

**Special case of  
event structures with symmetry:**

# Lifting properties

A functor  $p : \mathbb{C} \rightarrow \mathbb{D}$  is a

- a **discrete fibration** if it has **unique** lifts
- a **Grothendieck fibration** if it has **cartesian** lifts
- a **Street fibration** if it has **cartesian *pseudo-lifts***

**Special case of  
event structures with symmetry:**

# Lifting properties

A functor  $p : \mathbb{C} \rightarrow \mathbb{D}$  is a

- a **discrete fibration** if it has **unique lifts**
- a **Grothendieck fibration** if it has **cartesian lifts**
- a **Street fibration** if it has **cartesian *pseudo-lifts***

## Special case of event structures with symmetry:

**Prop.** For functors  $\sigma : \mathcal{C}(S) \rightarrow \mathcal{C}(A^\perp \parallel B)$ ,

- **discrete fibration**  $\iff$  **unique lifts**
- **Grothendieck fibration**  $\iff$  **essentially unique lifts**
- **Street fibration**  $\iff$  **essentially unique pseudo-lifts**

# Lifting properties

A functor  $p : \mathbb{C} \rightarrow \mathbb{D}$  is a

- a **discrete fibration** if it has **unique lifts**
- a **Grothendieck fibration** if it has **cartesian lifts**
- a **Street fibration** if it has **cartesian *pseudo-lifts***

## Special case of event structures with symmetry:

**Prop.** For functors  $\sigma : \mathcal{C}(S) \rightarrow \mathcal{C}(A^\perp \parallel B)$ ,

- **discrete fibration**  $\iff$  **unique lifts**
- **Grothendieck fibration**  $\iff$  **essentially unique lifts**
- **Street fibration**  $\iff$  **essentially unique pseudo-lifts**

*(because all fibres are setoids)*

# Main theorem.

*$\sigma$  is a weak strategy*

$$\text{id}_B \circ \sigma \circ \text{id}_A \simeq \sigma$$



*$\sigma : \mathcal{C}(S) \rightarrow \mathcal{C}(A^\perp \parallel B)$*

*is a Street fibration for*

$$\underline{\supseteq}^{\blacksquare} \cdot \underline{\simeq} \cdot \underline{\subseteq}^{\blacksquare}$$

*= essentially unique pseudo lifts for  $\underline{\supseteq}^{\blacksquare}$  and  $\underline{\subseteq}^{\blacksquare}$*

# Main theorem.

*$\sigma$  is a weak strategy*

$$\text{id}_B \circ \sigma \circ \text{id}_A \simeq \sigma$$



*$\sigma : \mathcal{C}(S) \rightarrow \mathcal{C}(A^\perp \parallel B)$*

*is a Street fibration for*

$$\underline{\supseteq}^{\blacksquare} \cdot \simeq \cdot \underline{\subseteq}^{\blacksquare}$$

*= essentially unique pseudo lifts for  $\underline{\supseteq}^{\blacksquare}$  and  $\underline{\subseteq}^{\blacksquare}$*



free isofibration

*essentially unique lifts for  $\underline{\supseteq}^{\blacksquare}$  and  $\underline{\subseteq}^{\blacksquare}$*

# Main theorem.

$\sigma$  is a weak strategy

$$\text{id}_B \circ \sigma \circ \text{id}_A \simeq \sigma$$



$\sigma : \mathcal{C}(S) \rightarrow \mathcal{C}(A^\perp \parallel B)$

is a Street fibration for

$$\supseteq^{\blacksquare} \cdot \simeq \cdot \subseteq^{\blacksquare}$$

= essentially unique pseudo lifts for  $\supseteq^{\blacksquare}$  and  $\subseteq^{\blacksquare}$

free isofibration

essentially unique lifts for  $\supseteq^{\blacksquare}$  and  $\subseteq^{\blacksquare}$

unique lifts for  $\supseteq^{\blacksquare}$  and  $\subseteq^{\blacksquare}$

collapse construction

**HARD**

# Main theorem.

$\sigma$  is a weak strategy

$$\text{id}_B \circ \sigma \circ \text{id}_A \simeq \sigma$$

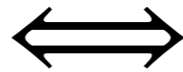

$\sigma : \mathcal{C}(S) \rightarrow \mathcal{C}(A^\perp \parallel B)$

is a Street fibration for

$$\supseteq^{\blacksquare} \cdot \simeq \cdot \subseteq^{\blacksquare}$$

= essentially unique pseudo lifts for  $\supseteq^{\blacksquare}$  and  $\subseteq^{\blacksquare}$

↑  
strong strategy

↑  
unique lifts for  $\supseteq^{\blacksquare}$  and  $\subseteq^{\blacksquare}$

collapse construction  
←  
**HARD**

free isofibration  
↓

essentially unique lifts for  $\supseteq^{\blacksquare}$  and  $\subseteq^{\blacksquare}$

# Two more results.

1. Representation of strategies as profunctors.

$$\sigma : \mathcal{C}(\sigma) \longrightarrow \mathcal{C}(A^\perp \parallel B) \xrightarrow{\cong} \mathcal{C}(A)^{\text{op}} \times \mathcal{C}(B)$$

This is a Street fibration so essential fibres determine a pseudo-functor:

$$\sigma : \mathcal{C}(A) \times \mathcal{C}(B)^{\text{op}} \longrightarrow \mathbf{Setoid}$$

**Thm.** oplax functor of tricategories  $\mathbf{Strat} \longrightarrow \mathbf{SetoidProf}$ .

# Two more results.

1. Representation of strategies as profunctors.

$$\sigma : \mathcal{C}(\sigma) \longrightarrow \mathcal{C}(A^\perp \parallel B) \xrightarrow{\cong} \mathcal{C}(A)^{\text{op}} \times \mathcal{C}(B)$$

This is a Street fibration so essential fibres determine a pseudo-functor:

$$\sigma : \mathcal{C}(A) \times \mathcal{C}(B)^{\text{op}} \longrightarrow \mathbf{Setoid}$$

**Thm.** oplax functor of tricategories  $\mathbf{Strat} \longrightarrow \mathbf{SetoidProf}$ .

2. Embedding of thin concurrent games  $\mathbf{Thin} \hookrightarrow \mathbf{Strat}$   
*(relevant to many applications in game semantics.)*

# Summary

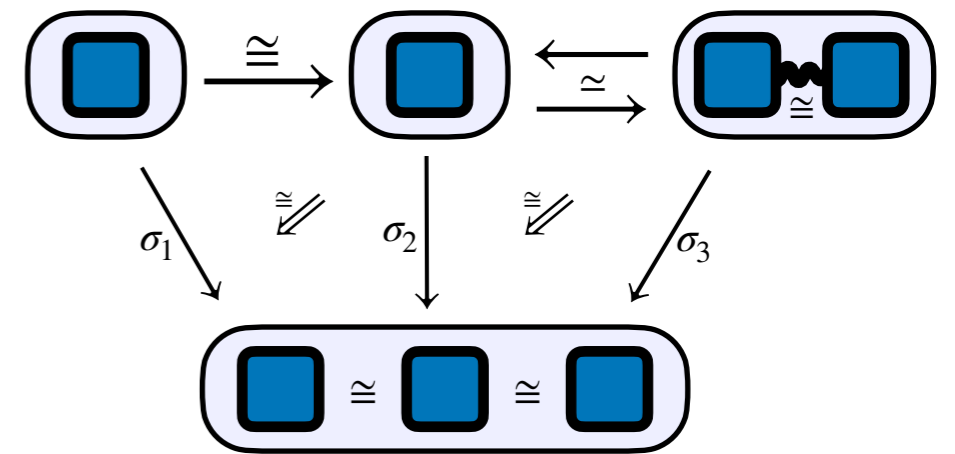

Categorical foundations for games and strategies on event structures with symmetry.

**2013:** Concurrent strategies as discrete fibrations

**Now:** Concurrent strategies with symmetry as Street fibrations.

All reasoning up to symmetry/homotopy. Maybe better for a type-theoretic formalization?

*Example of a pre-strategy which is not a strategy:*

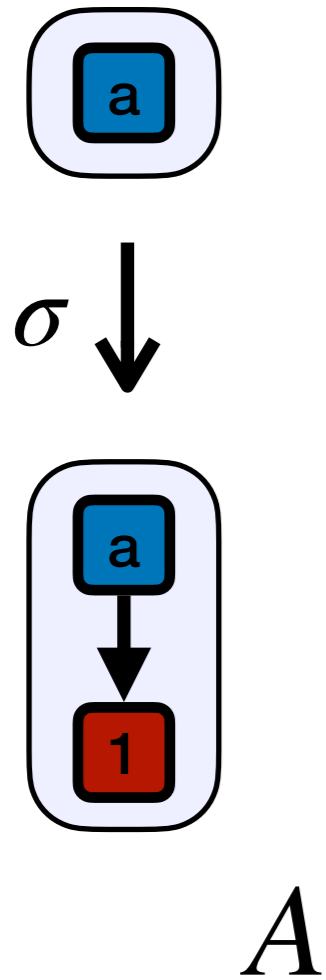

*Example of a pre-strategy which is not a strategy:*

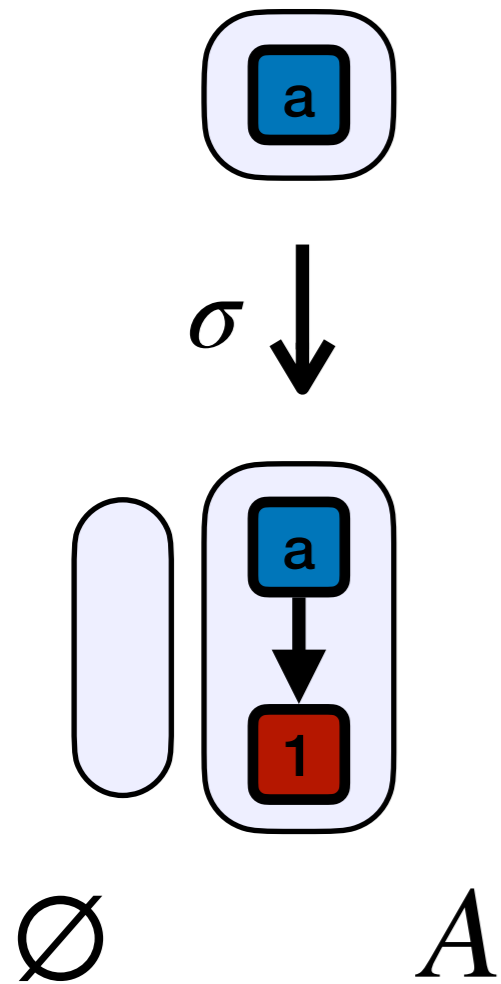

*Example of a pre-strategy which is not a strategy:*

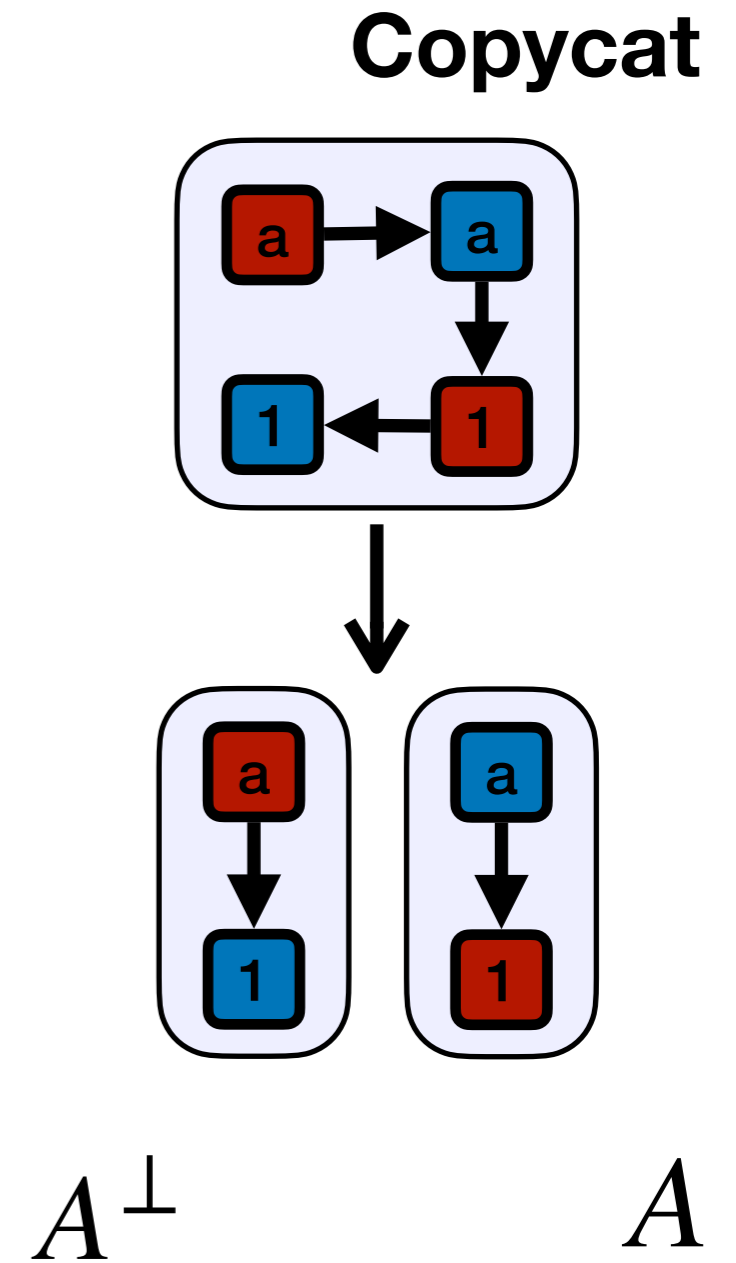
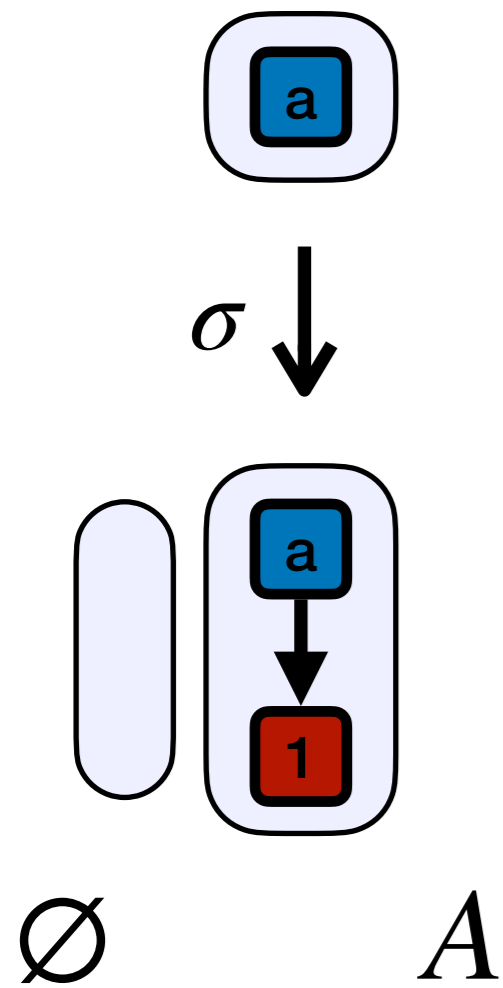

*Example of a pre-strategy which is not a strategy:*

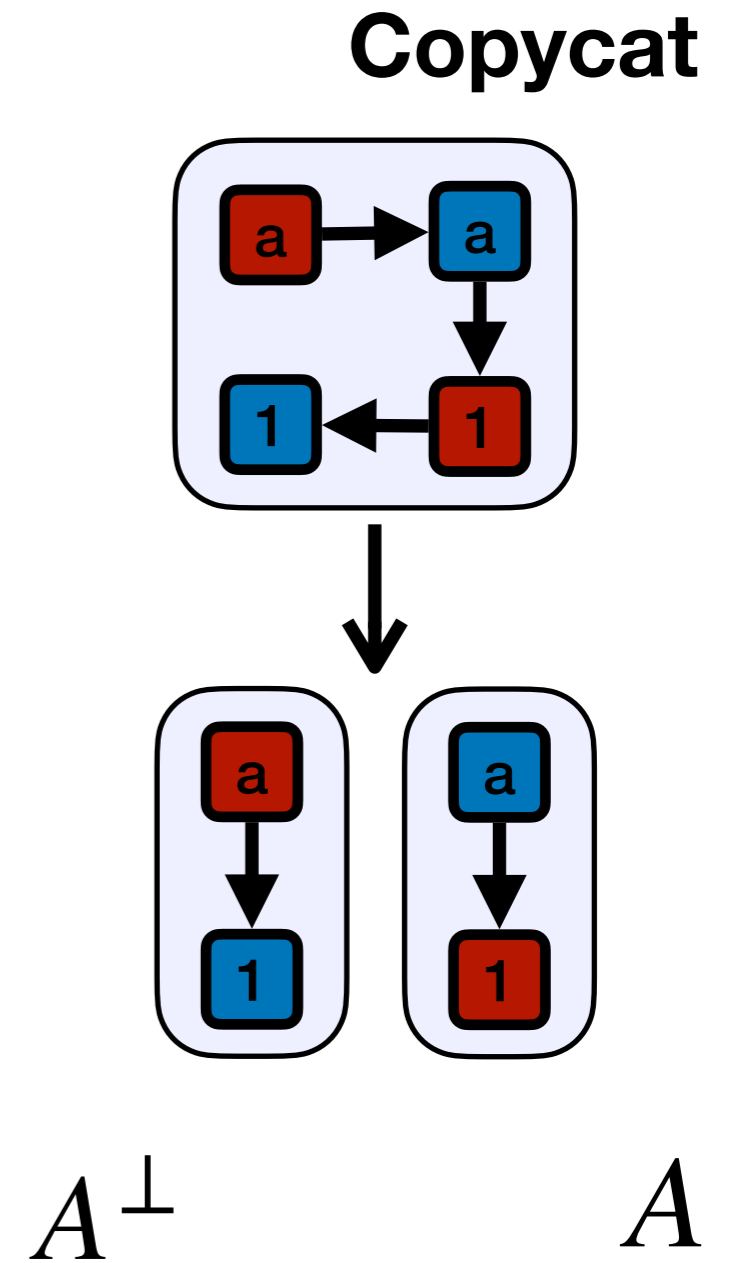
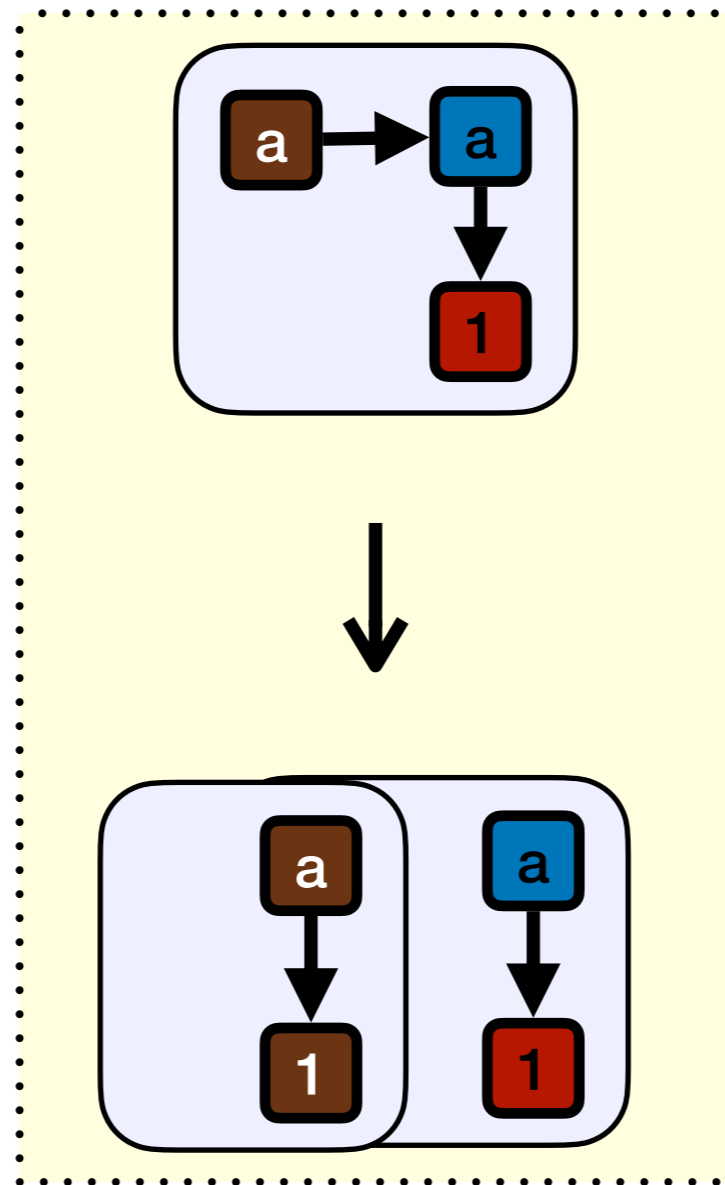
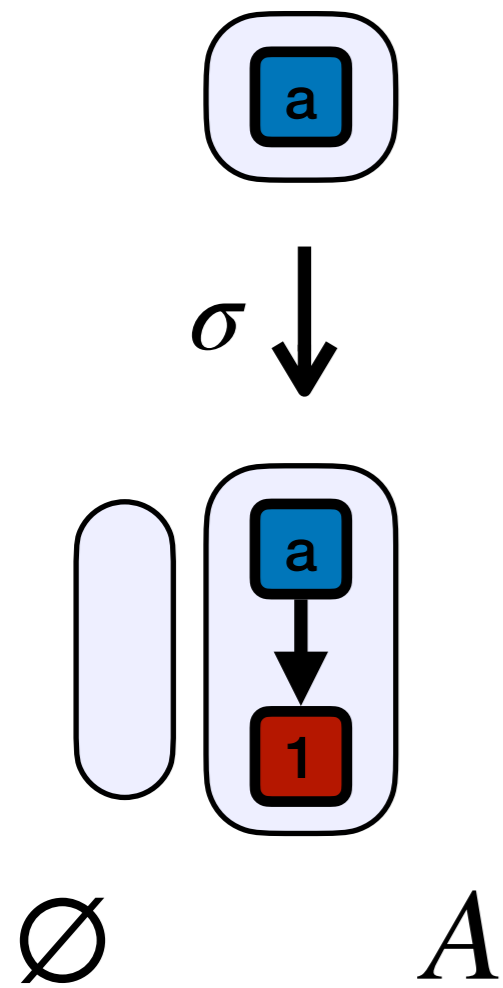

*Example of a pre-strategy which is not a strategy:*

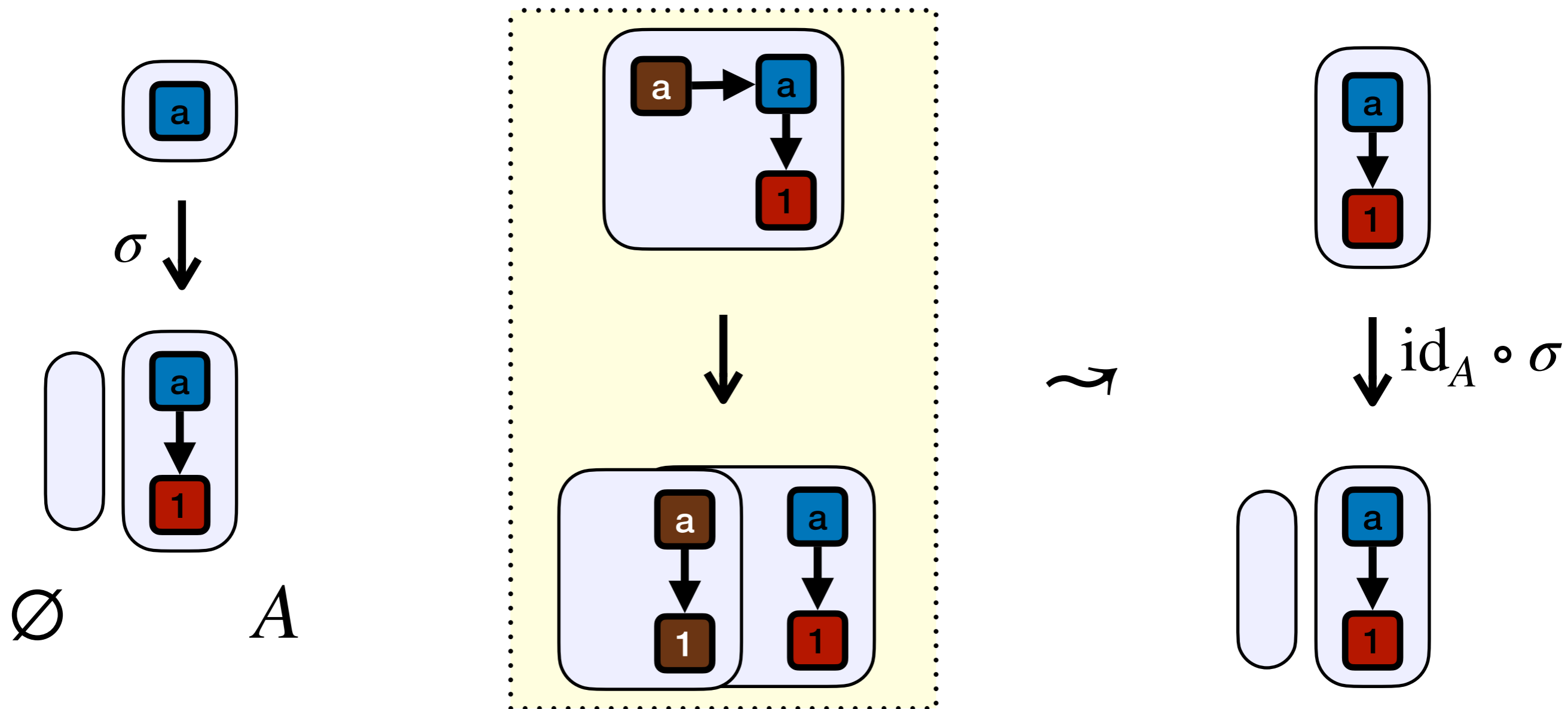

*Example of a pre-strategy which is not a strategy:*

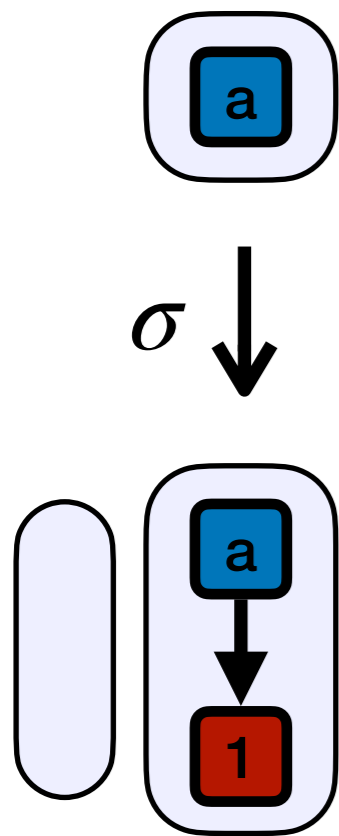

$\neq$

